

TUNING FORK CRYSTAL UNIT IN SMD 7.5x3.1MM RESIN MOLD PACKAGE.
PRODUCT FEATURES

- Package dimensions 7.5x3.1x2.3 with 2 leads.
- Heat resistant mold allowing high temperature reflow.
- Suitable for low power consumption applications.
- RoHS compliant, LEAD-FREE and HALOGEN-FREE.

PRODUCT PHOTO (NOT IN SCALE)

APPLICATIONS

- Real time clocks
- Microprocessors
- Timers and controllers
- Meters and handheld devices

PRODUCT SPECIFICATIONS

PARAMETER	3437S	CONDITIONS / REMARKS
Nominal frequency range	32.768kHz	---
Vibration mode	Fundamental	---
Frequency tolerance	±20ppm / ±30ppm	Other options available.
Stability over temperature	-0.04ppm/°C ² MAX	Parabolic coefficient.
Operating temperature range	-20 to +70°C or -40 to +85°C	Other options available.
Turnover temperature	+25±5°C	---
Equivalent series resistance (ESR)	<65kΩ	@ Series load
Shunt capacitance	0.8pF	---
Motional capacitance	3.2fF	---
Load capacitance	7pF / 9pF / 12.5pF	Please specify.
Drive level	0.1μW TYP / 1.0μW MAX	---
Aging per year	±3ppm	At +25°C

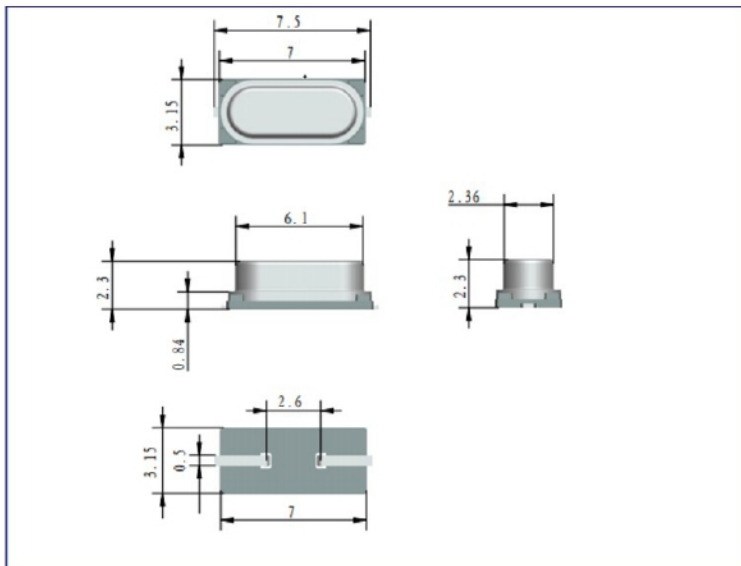
PACKAGE OUTLINE / DIMENSIONS

PACKAGING INFORMATION

- Tape & Reel compliant to EIA-481.
- Embossed carrier width 16mm.
- Component pitch in carrier 8mm.
- Reel diameter 330mm.
- QTY per reel: 1,000pcs

RECOMMENDED REFLOW PROFILE
