

# LBSS5240LT1G

## S-LBSS5240LT1G

General Purpose Transistors PNP Silicon

### 1. FEATURES

- Low collector-emitter saturation voltage
- High current capability
- Improved device reliability due to reduced heat generation
- We declare that the material of product compliance with RoHS requirements and Halogen Free.
- S- prefix for automotive and other applications requiring unique site and control change requirements; AEC-Q101 qualified and PPAP capable.

### 2. APPLICATIONS

- Supply line switching circuits
- Battery management applications
- DC/DC converter applications
- Strobe flash units
- Heavy duty battery powered equipment (motor and lamp drivers).

### 3. DEVICE MARKING AND ORDERING INFORMATION

Device	Marking	Shipping
LBSS5240LT1G	ZF	3000/Tape&Reel
LBSS5240LT3G	ZF	10000/Tape&Reel

### 4. MAXIMUM RATINGS(Ta = 25°C)

Parameter	Symbol	Limits	Unit
Collector-Emitter Voltage	VCEO	-40	V
Collector-Base voltage	VCBO	-40	V
Emitter-Base Voltage	VEBO	-5	V
Collector current-continuous	IC	-2	A
Peak collector current(tp < 1 ms)	ICM	-6	A
Power dissipation	PD	0.3	W
Junction temperature	TJ	-55~+150	°C
Storage temperature	TSTG	-55~+150	°C

### 5. THERMAL CHARACTERISTICS

Parameter	Symbol	Value	Unit
Thermal resistance from junction to ambient in free air	(Note 1)	417	K/W
	(Note 2)	260	K/W

1. Device mounted on a printed-circuit board, single sided copper, tinplated and standard footprint.

2. Device mounted on a printed-circuit board, single sided copper, tinplated and mounted pad for collector 1 cm<sup>2</sup>.

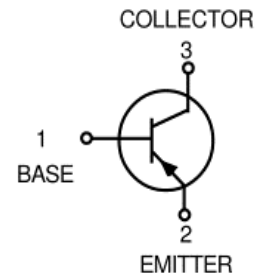
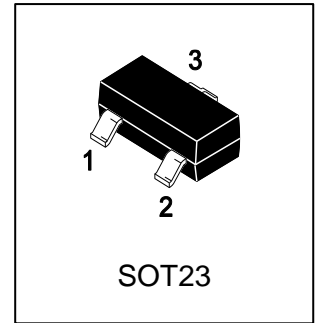

**6. ELECTRICAL CHARACTERISTICS (Ta= 25°C)**

Characteristic	Symbol	Min.	Typ.	Max.	Unit
Collector–Emitter Breakdown Voltage (IC= -10mA,IB= 0A)	VBR(CEO)	-40	-	-	V
Collector–Base Breakdown Voltage (IC= -100μA,IE= 0A)	VBR(CBO)	-40	-	-	V
Emitter–Base Breakdown Voltage (IE= -100μA,IC= 0A)	VBR(EBO)	-5	-	-	V
Collector-Base cut-off current (IE = 0, VCB = -30 V)	ICBO	-	-	-100	nA
Emitter-Base cut-off current (IC = 0, VBE = -4 V)	IEBO	-	-	-100	nA
Collector-Emitter cutoff Current (VCE = -40V, IB=0)	ICEO	-	-	-100	μA
DC current gain (VCE = -2 V,IC = -100 mA) (VCE = -2 V,IC = -500 mA) (VCE = -2 V,IC = -1 A) (VCE = -2 V,IC = -2 A)	hFE	300 260 210 100	- - - -	- - - -	
Collector-Emitter saturation voltage (IC = -100 mA, IB = -1 mA) (IC = -500 mA, IB = -50 mA) (IC = -750 mA, IB = -15 mA) (IC = -1 A, IB = -50 mA) (IC = -2 A, IB = -200 mA)	VCE(sat)	- - - - -	- - - - -	-100 -110 -225 -225 -350	mV
Base-Emitter saturation voltage (IC = -2 A,IB = -200 mA)	VBE(sat)	-	-	-1.1	V
Base-Emitter turn on voltage (IC = -100 mA,VCE = -2 V)	VBE(on)	-	-	-0.75	V
Transition frequency (IC = -100 mA,VCE = -10 V, f = 100 MHz)	fT	100	-	-	MHz
Collector capacitance (IE = Ie = 0,VCB = -10 V,f = 1 MHz)	Cc	-	-	28	pF

**7. ELECTRICAL CHARACTERISTICS CURVES(Ta=25°C)**

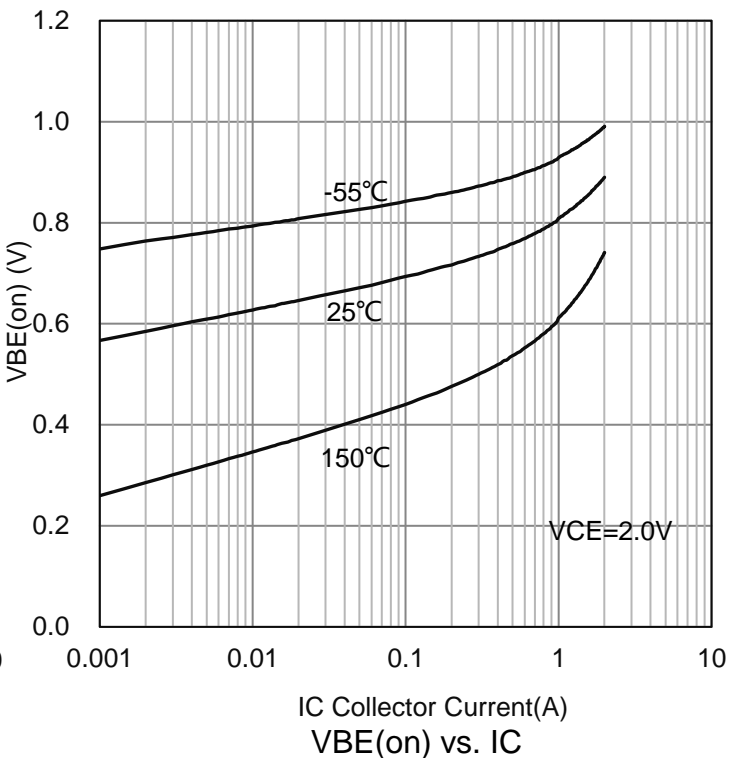
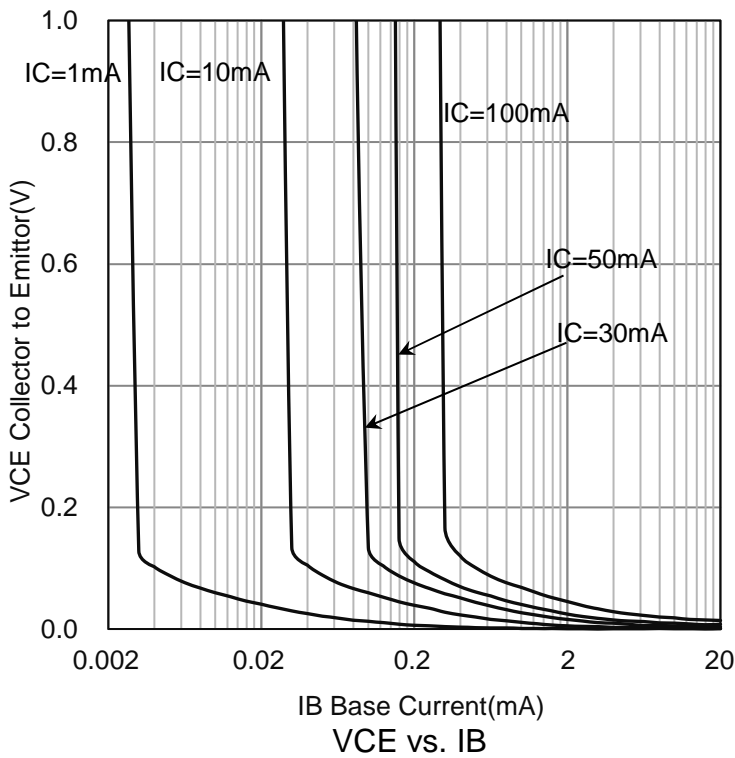
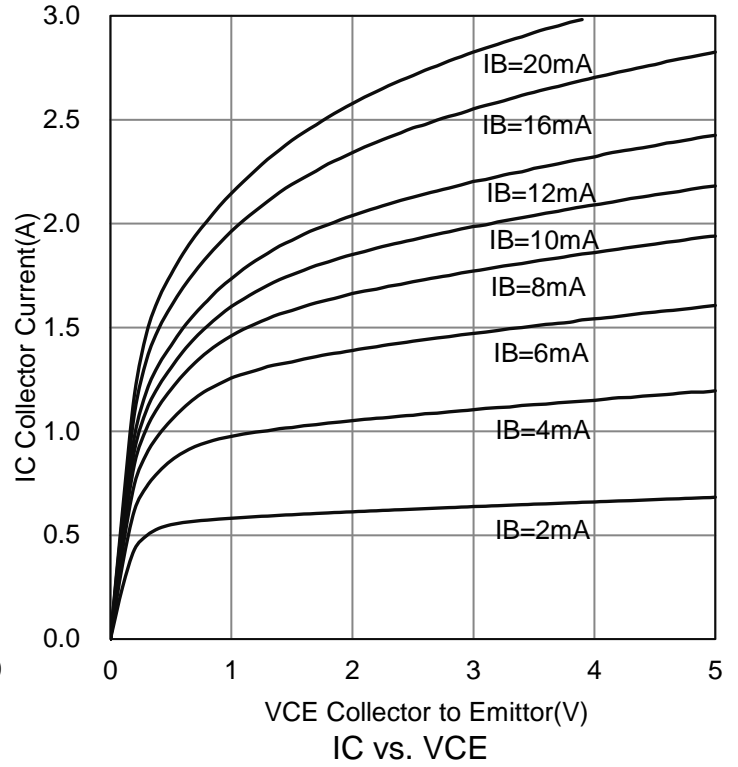
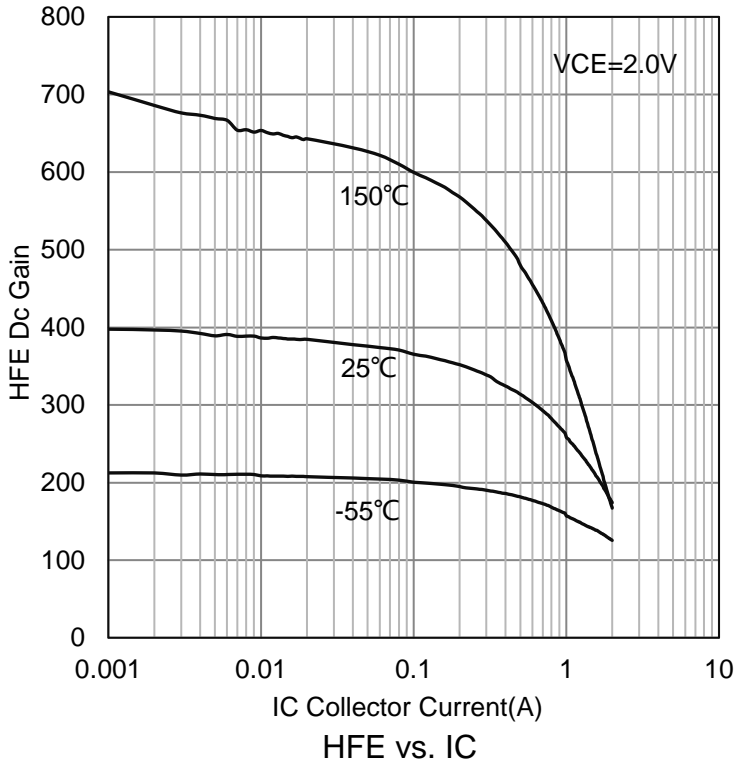

**7. ELECTRICAL CHARACTERISTICS CURVES(Ta=25°C)(Con.)**

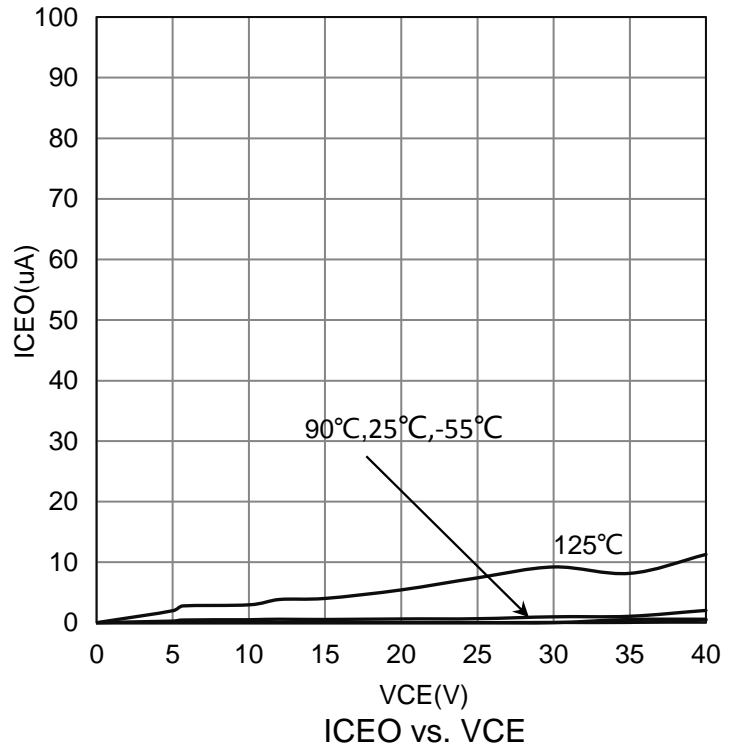
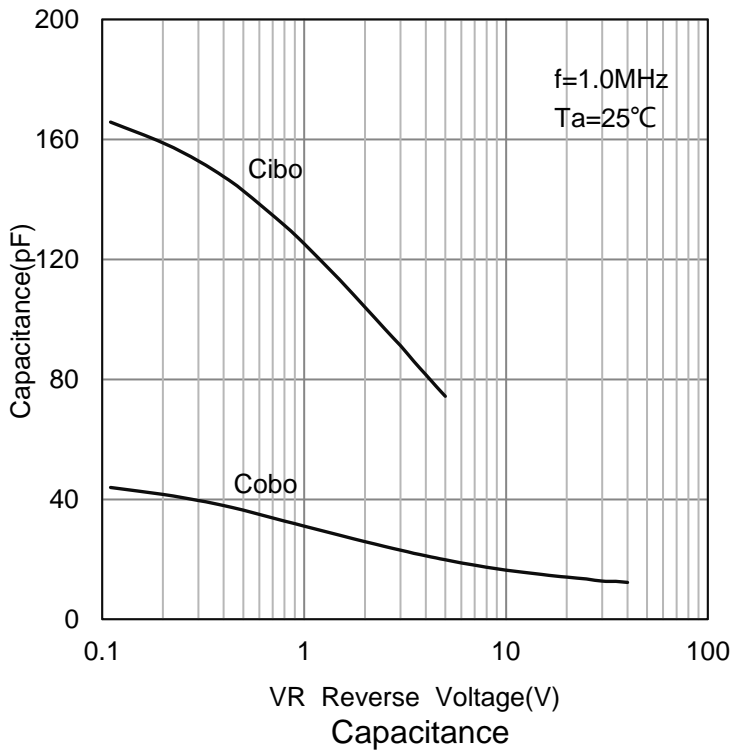
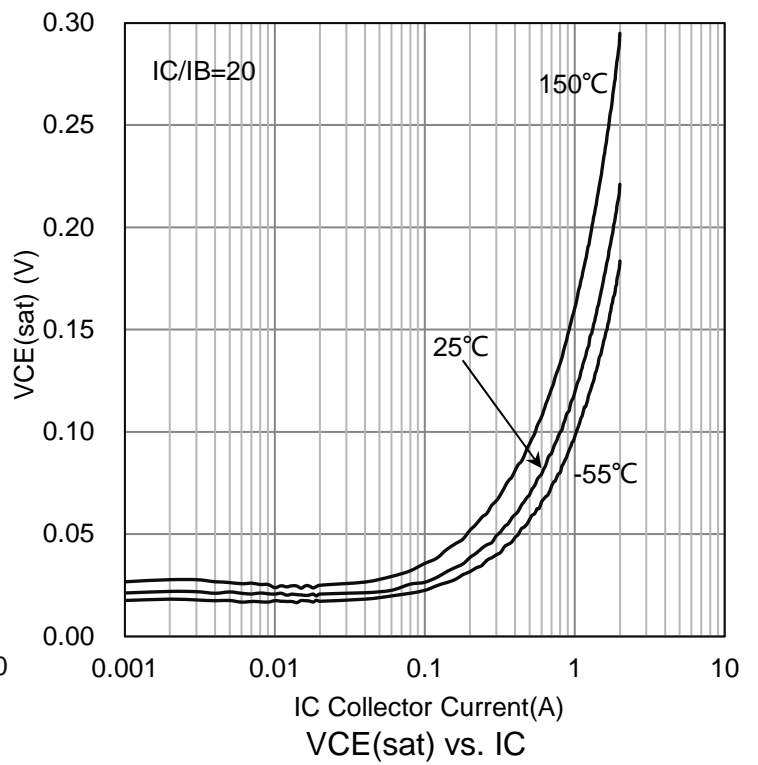
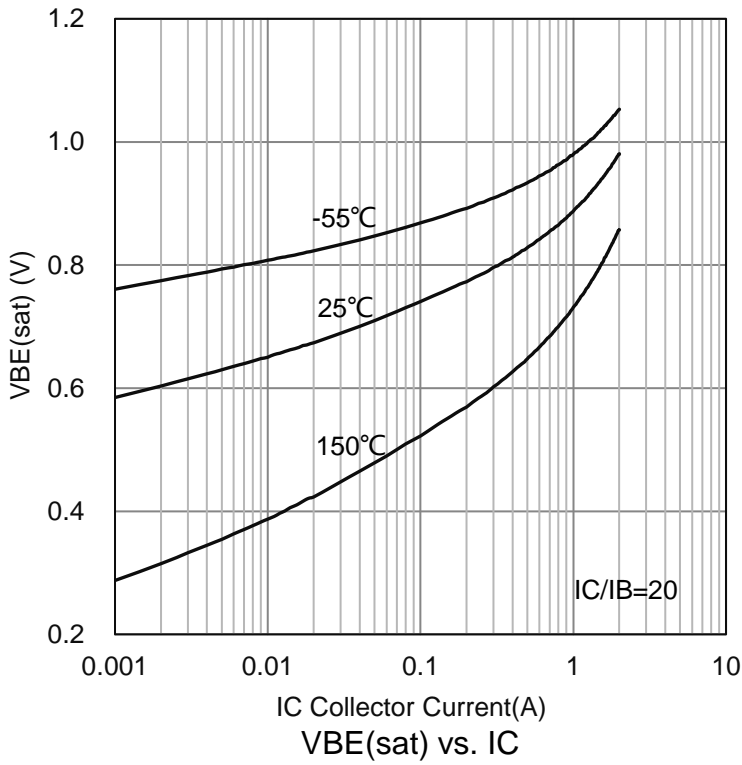

7. ELECTRICAL CHARACTERISTICS CURVES(Ta=25°C)(Con.)

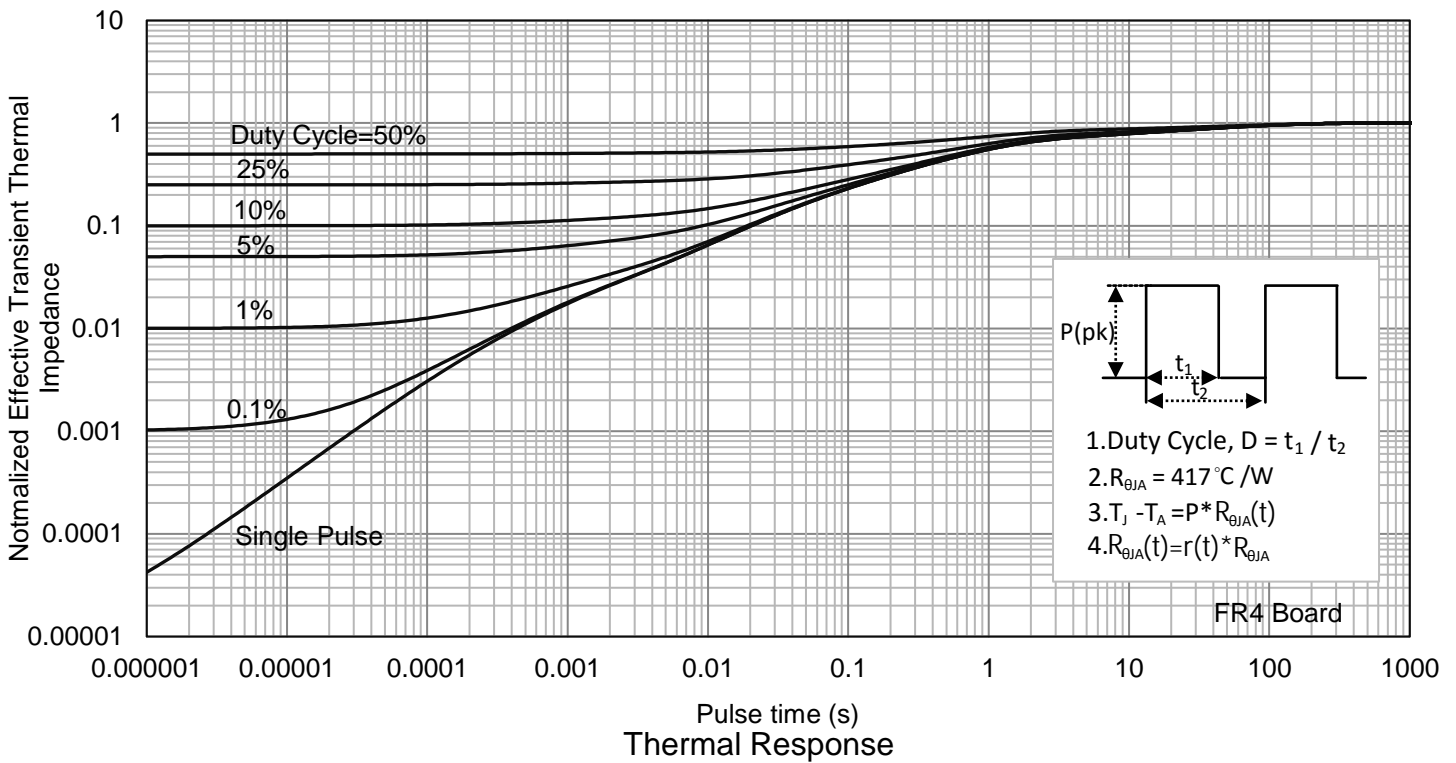
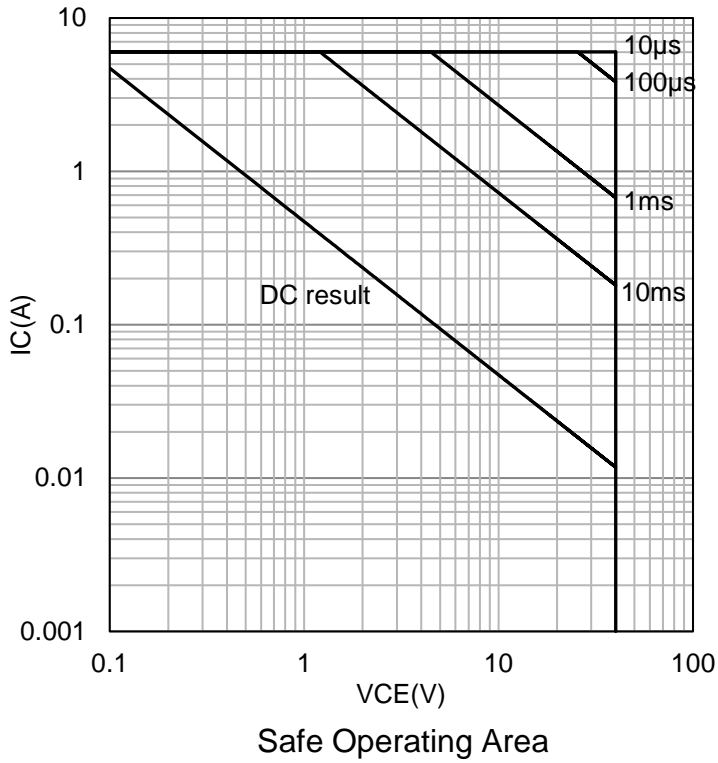

### 8.OUTLINE AND DIMENSIONS

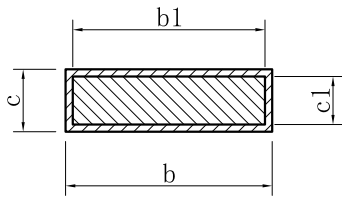
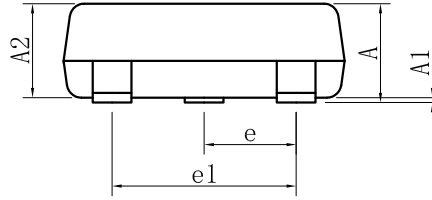
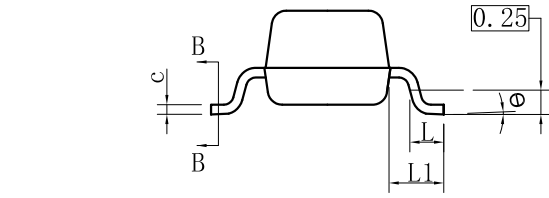

SECTION B-B

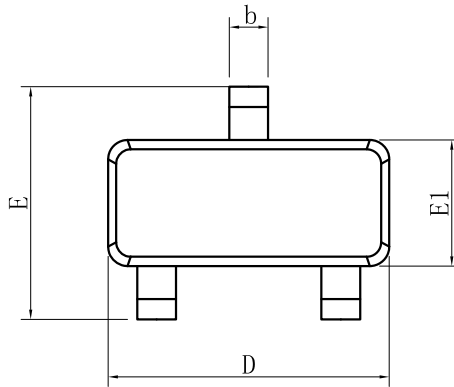

SOT23			
DIM	MIN	NOR	MAX
A	0.89	-	1.12
A1	0.01	-	0.10
A2	0.88	0.95	1.02
b	0.30	-	0.50
b1	0.30	0.40	0.45
c	0.08	-	0.20
c1	0.08	0.10	0.16
D	2.80	2.90	3.04
E	2.10	-	2.64
E1	1.20	1.30	1.40
e	0.95BSC		
e1	1.90BSC		
L	0.40	0.46	0.60
L1	0.54REF		
θ	0°	-	8°
All Dimensions in mm			

#### GENERAL NOTES

1. Top package surface finish Ra0.4±0.2um
2. Bottom package surface finish Ra0.7±0.2um
3. Side package surface finish Ra0.4±0.2um

### 9.SOLDERING FOOTPRINT

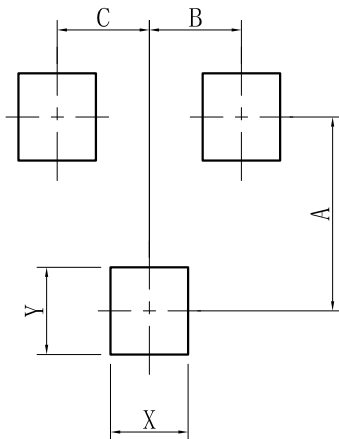

SOT-23	
DIM	(mm)
X	0.80
Y	0.90
A	2.00
B	0.95
C	0.95

## **DISCLAIMER**

- Curve guarantee in the specification. The curve of test items with electric parameter is used as quality guarantee. The curve of test items without electric parameter is used as reference only.
- Before you use our Products for new Project, you are requested to carefully read this document and fully understand its contents. LRC shall not be in any way responsible or liable for failure, malfunction or accident arising from the use of any LRC's Products against warning, caution or note contained in this document.
- All information contained in this document is current as of the issuing date and subject to change without any prior notice. Before purchasing or using LRC's Products, please confirm the latest information with a LRC sales representative.