

L1SS184LT1G

S-L1SS184LT1G

Ultra High Speed Switching Application

1. FEATURES

- Low forward voltage :VF (3) = 0.9V (typ.)
- Fast reverse recovery time : trr = 1.6ns (typ.)
- Small total capacitance : CT = 0.9pF (typ.)
- We declare that the material of product compliance with RoHS requirements and Halogen Free.
- S- prefix for automotive and other applications requiring unique site and control change requirements; AEC-Q101 qualified and PPAP capable.

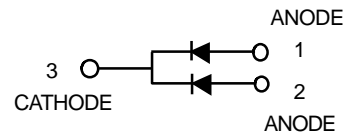
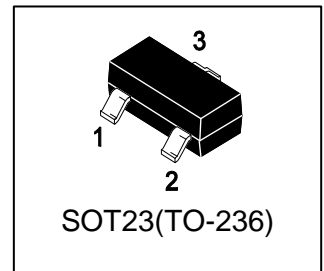

2. DEVICE MARKING AND RESISTOR VALUES

Device	Marking	Shipping
L1SS184LT1G	B3	3000/Tape&Reel
L1SS184LT3G	B3	10000/Tape&Reel

3. MAXIMUM RATINGS(Ta = 25°C)

Parameter	Symbol	Limits	Unit
Maximum (peak) reverse voltage	VRM	85	V
Reverse voltage	VR	80	V
Maximum (peak) forward current	IFM	300(Note 1)	mA
Average forward current	IO	100(Note 1)	mA
Surge current (10ms)	IFSM	2(Note 1)	A
Power dissipation	P	150	mW
Junction temperature	Tj	125	°C
Storage temperature range	Tstg	-55 to +125	°C

1. Unit rating. Total rating = Unit rating × 0.7.

4. ELECTRICAL CHARACTERISTICS (Ta= 25°C)

CHARACTERISTICS	Symbol	Min	Typ.	Max	Unit
Forward voltage (IF =1mA)	VF	-	0.6	-	V
(IF =10mA)		-	0.72	-	
(IF =100mA)		-	0.9	1.2	
Reverse current (VR = 30V)	IR	-	-	0.1	μA
(VR=80V)		-	-	0.5	
Total capacitance (f=1MHz, VR =0)	CT	-	0.9	3	pF
Reverse Recovery Time (IF=10mA)	Trr	-	1.6	4	nS

5.ELECTRICAL CHARACTERISTICS CURVES

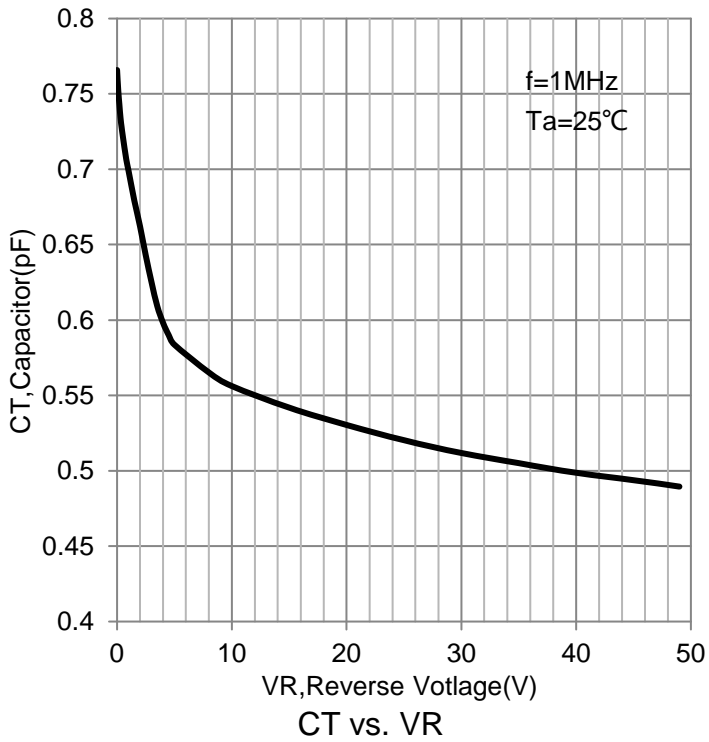
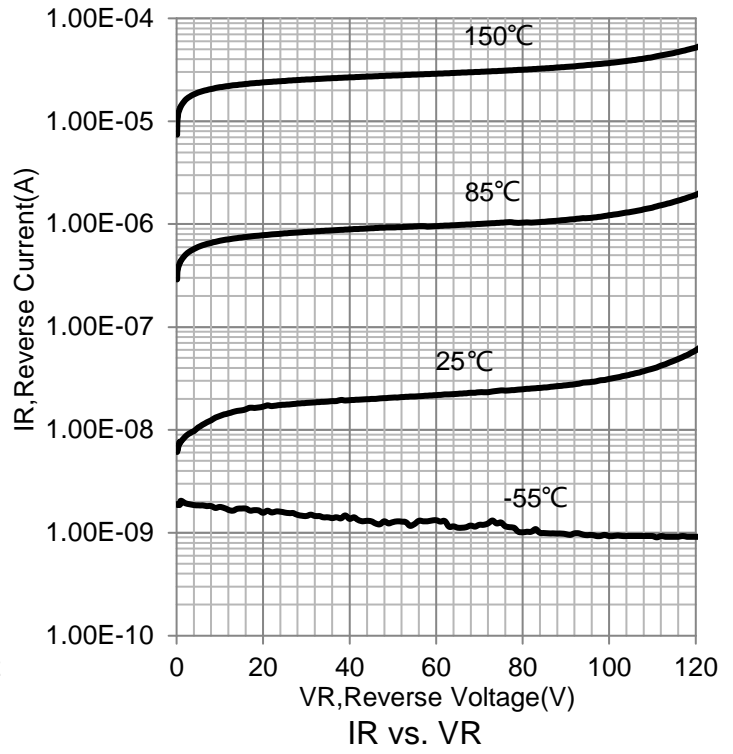
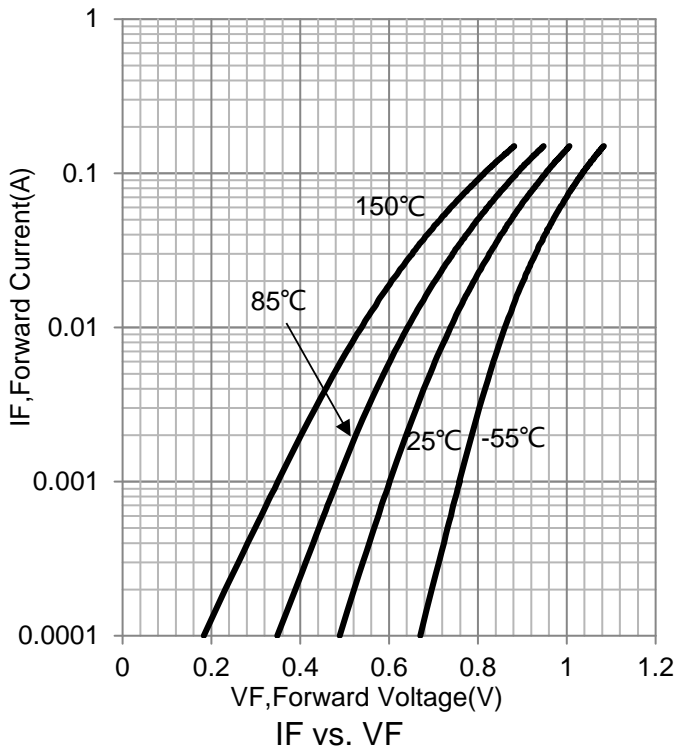

6. OUTLINE AND DIMENSIONS

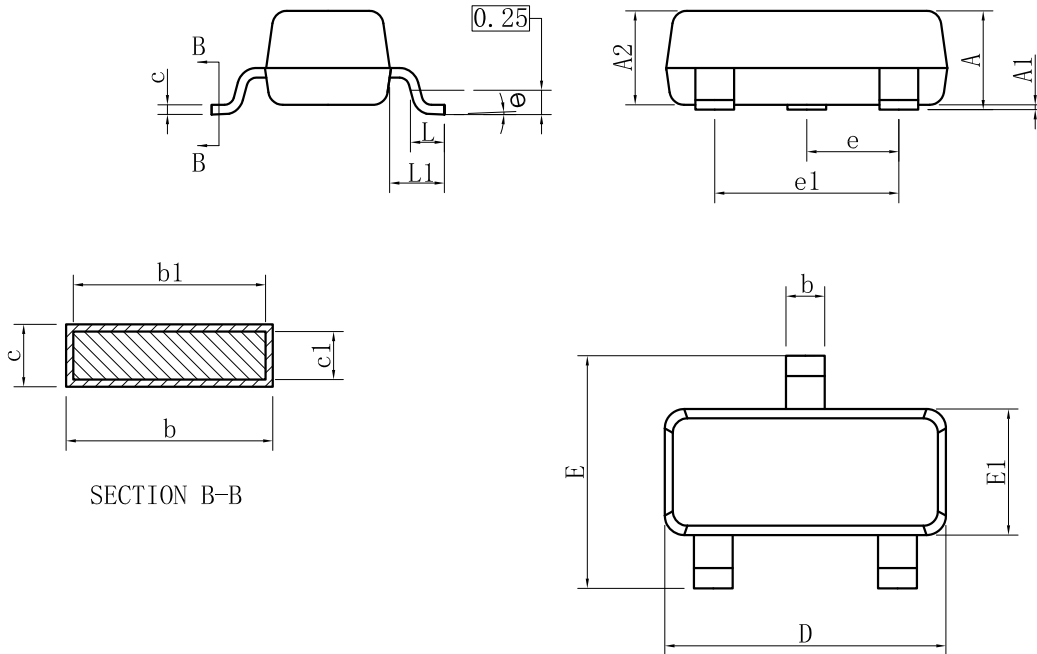

SOT23			
DIM	MIN	NOR	MAX
A	0.89	-	1.12
A1	0.01	-	0.10
A2	0.88	0.95	1.02
b	0.30	-	0.50
b1	0.30	0.40	0.45
c	0.08	-	0.20
c1	0.08	0.10	0.16
D	2.80	2.90	3.04
E	2.10	-	2.64
E1	1.20	1.30	1.40
e	0.95BSC		
e1	1.90BSC		
L	0.40	0.46	0.60
L1	0.54REF		
θ	0°	-	8°
All Dimensions in mm			

GENERAL NOTES

1. Top package surface finish $Ra0.4 \pm 0.2\mu m$
2. Bottom package surface finish $Ra0.7 \pm 0.2\mu m$
3. Side package surface finish $Ra0.4 \pm 0.2\mu m$

7. SOLDERING FOOTPRINT

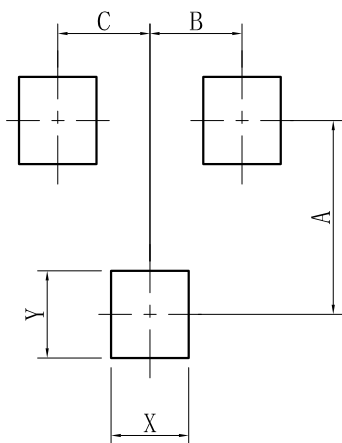

SOT-23	
DIM	(mm)
X	0.80
Y	0.90
A	2.00
B	0.95
C	0.95

DISCLAIMER

- Curve guarantee in the specification. The curve of test items with electric parameter is used as quality guarantee. The curve of test items without electric parameter is used as reference only.
- Before you use our Products for new Project, you are requested to carefully read this document and fully understand its contents. LRC shall not be in any way responsible or liable for failure, malfunction or accident arising from the use of any LRC's Products against warning, caution or note contained in this document.
- All information contained in this document is current as of the issuing date and subject to change without any prior notice. Before purchasing or using LRC's Products, please confirm the latest information with a LRC sales representative.