

EMC 性能优异的 ISO776x 高速、增强型六通道数字隔离器

1 特性

- 100Mbps 数据速率
- 稳健可靠的隔离栅：
 - 预计寿命超过 100 年
 - 高达 5000V 的 V_{RMS} 隔离额定值
 - 高达 12.8kV 的浪涌能力
 - CMTI 典型值为 $\pm 100\text{kV}/\mu\text{s}$
- 宽电源范围：2.25V 至 5.5V
- 2.25V 至 5.5V 电平转换
- 默认输出高电平 (ISO776x) 和低电平 (ISO776xF) 选项
- 宽温度范围：-55°C 至 +125°C
- 低功耗，1Mbps 时每通道的电流典型值为 1.4mA
- 低传播延迟：5V 时的典型值为 11ns
- 优异的电磁兼容性 (EMC)：
 - 系统级 ESD、EFT 和浪涌抗扰性
 - $\pm 8\text{kV}$ IEC 61000-4-2 跨隔离栅接触放电保护
 - 低辐射
- 宽体 SOIC (DW-16) 和 SSOP (DBQ-16) 封装选项
- 可用的汽车版本：ISO776x-Q1
- 安全相关认证：
 - 符合 DIN V VDE V 0884-11:2017-01 标准的增强型绝缘
 - UL 1577 组件认证计划
 - 获得 CSA 认证，符合 IEC 60950-1、IEC 62368-1 和 IEC 60601-1 标准的 CSA 认证措辞
 - 符合 GB4943.1-2011 的 CQC 认证
 - 符合 EN 60950-1 和 EN 61010-1 的 TUV 认证

2 应用

- 工业自动化
- 电机控制
- 电源
- 光伏逆变器
- 医疗设备

3 说明

ISO776x 器件是高性能六通道数字隔离器，可提供符合 UL 1577 的 5000V_{RMS} (DW 封装) 和 3000V_{RMS} (DBQ 封装) 隔离额定值。该系列器件还通过了 VDE、CSA、TUV 和 CQC 认证。

在隔离 CMOS 或 LVCMOS 数字 I/O 的同时，ISO776x 系列的器件还可提供高电磁抗扰度和低辐射，同时具备低功耗特性。每个隔离通道都有一个由二氧化硅 (SiO₂) 绝缘栅分开的逻辑输入和逻辑输出缓冲器。ISO776x 系列的器件采用所有可能的引脚配置，因此所有六个通道都可以处于同一方向，或者一个、两个或三个通道处于反向，而其余通道处于正向。如果输入功率或信号出现损失，不带后缀 F 的器件默认输出高电平，带后缀 F 的器件默认输出低电平。有关更多详细信息，请参阅 [器件功能模式](#) 部分。

该系列器件与隔离式电源结合使用，有助于防止数据总线（例如，RS-485、RS-232 和 CAN）或者其他电路上的噪声电流进入本地接地以及干扰或损坏敏感电路。凭借创新型芯片设计和布局技术，ISO776x 系列器件的电磁兼容性得到了显著增强，可缓解系统级 ESD、EFT 和浪涌问题并符合辐射标准。ISO776x 系列器件可采用 16 引脚 SOIC 和 SSOP 封装。

器件信息⁽¹⁾

器件型号	封装	封装尺寸 (标称值)
ISO7760 ISO7761 ISO7762 ISO7763	SOIC (16)	10.30mm x 7.50mm
	SSOP (16)	4.90mm x 3.90mm

(1) 如需了解所有可用封装，请参阅数据表末尾的可订购产品附录。

简化原理图

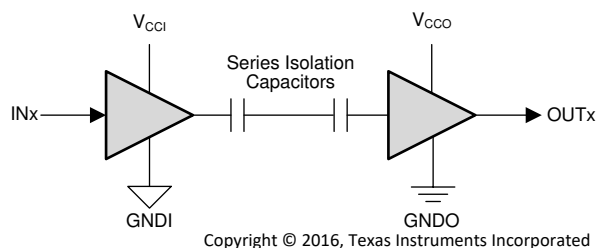

V_{CCI} =输入 V_{CC} , V_{CCO} =输出 V_{CC}
 $GNDI$ =输入接地, $GNDO$ =输出接地

目录

1 特性	1	6.19 Typical Characteristics	19
2 应用	1	7 Parameter Measurement Information	22
3 说明	1	8 Detailed Description	23
4 修订历史记录	2	8.1 Overview	23
5 Pin Configuration and Functions	4	8.2 Functional Block Diagram	23
6 Specifications	6	8.3 Feature Description	24
6.1 Absolute Maximum Ratings	6	8.4 Device Functional Modes	25
6.2 ESD Ratings	6	9 Application and Implementation	26
6.3 Recommended Operating Conditions	6	9.1 Application Information	26
6.4 Thermal Information	7	9.2 Typical Application	26
6.5 Power Ratings	7	10 Power Supply Recommendations	30
6.6 Insulation Specifications	8	11 Layout	31
6.7 Safety-Related Certifications	9	11.1 Layout Guidelines	31
6.8 Safety Limiting Values	9	11.2 Layout Example	31
6.9 Electrical Characteristics—5-V Supply	10	12 器件和文档支持	32
6.10 Supply Current Characteristics—5-V Supply	11	12.1 文档支持	32
6.11 Electrical Characteristics—3.3-V Supply	12	12.2 相关链接	32
6.12 Supply Current Characteristics—3.3-V Supply	13	12.3 接收文档更新通知	32
6.13 Electrical Characteristics—2.5-V Supply	14	12.4 社区资源	32
6.14 Supply Current Characteristics—2.5-V Supply	15	12.5 商标	32
6.15 Switching Characteristics—5-V Supply	16	12.6 静电放电警告	32
6.16 Switching Characteristics—3.3-V Supply	16	12.7 术语表	33
6.17 Switching Characteristics—2.5-V Supply	17	13 机械、封装和可订购信息	34
6.18 Insulation Characteristics Curves	18		

4 修订历史记录

注：之前版本的页码可能与当前版本有所不同。

Changes from Revision D (November 2018) to Revision E	Page
• Changed CPG parameter description From: "External clearance" To: "External creepage" in Insulation Specifications table	8

Changes from Revision C (January 2018) to Revision D	Page
• 通篇进行了编辑性和修饰性更改	1
• 在特性中将“隔离栅寿命大于 40 年”更改为“预计寿命超过 100 年”	1
• 在特性中添加了“高达 5000V 的 V_{RMS} 隔离额定值”	1
• 在特性中添加了“高达 12.8kV 的浪涌能力”	1
• 在特性中添加了“±8kV IEC 61000-4-2 跨隔离栅接触放电保护”	1
• 在特性中添加了“可用的汽车版本：ISO776x-Q1”	1
• 通篇删除了“计划的认证”这一表述	1
• 更新了应用列表	1
• 更改了简化原理图，以显示串联隔离电容器	1
• Added "Contact discharge per IEC 61000-4-2" specification of ±8000 V in ESD Ratings table	6
• Added table note to <i>Data rate</i> specification in Recommended Operating Conditions table	6
• Changed V_{IORM} Value for DW-16 package From: "1414 V_{PK} " To: "2121 V_{PK} " in Insulation Specifications table	8
• Changed V_{IOWM} Values for DW-16 package From: "1000 V_{RMS} " and "1414 V_{DC} " To: "1500 V_{RMS} " and "2121 V_{DC} " in Insulation Specifications table	8
• Added 'see Figure 30 ' to TEST CONDITIONS of V_{IOWM} specification	8
• Updated certification information in Safety-Related Certifications table	9

• Changed From: "Table 2" To: "Safety Related Certifications" in Table 1 table note.....	24
• Changed Figure 23.....	25
• Added <i>Insulation Lifetime</i> sub-section under <i>Application Curves</i> section.....	29

Changes from Revision B (November 2017) to Revision C	Page
--	-------------

• Changed the C_{IO} value for the DBQ package from 1.1 to 0.9 pF in the <i>Insulation Specifications</i> table	8
---	---

Changes from Revision A (August 2017) to Revision B	Page
--	-------------

• 已更改 更改了特性和安全相关认证表	1
• 已更改 将 DBQ-16 封装的隔离电压从 2500 更改成了 $3000V_{RMS}$	1
• Added the maximum transient isolation voltage for the DW-16 package of the ISO7761, ISO7762, and ISO7763 devices in the <i>Insulation Specifications</i> and <i>Safety-Related Certifications</i> tables. Also changed the maximum value for the DBQ-16 package from 3600 to 4242 for all devcies	8
• Changed the table note and table condition for the <i>Safety Limiting Values</i>	9
• Added the supply current vs data rate graphs for the ISO7761, ISO7762, and ISO7763 in the <i>Typical Characteristics</i> section.....	19

Changes from Original (August 2017) to Revision A	Page
--	-------------

• Deleted EN from the <i>Common-Mode Transient Immunity Test Circuit</i> figure	22
• Changed the V_{CC1} and V_{CC2} signals in the <i>Typical ISO7761 Circuit Hook-up</i> figure.....	28

5 Pin Configuration and Functions

**ISO7760 DW and DBQ Packages
16-Pin SOIC and SSOP
Top View**

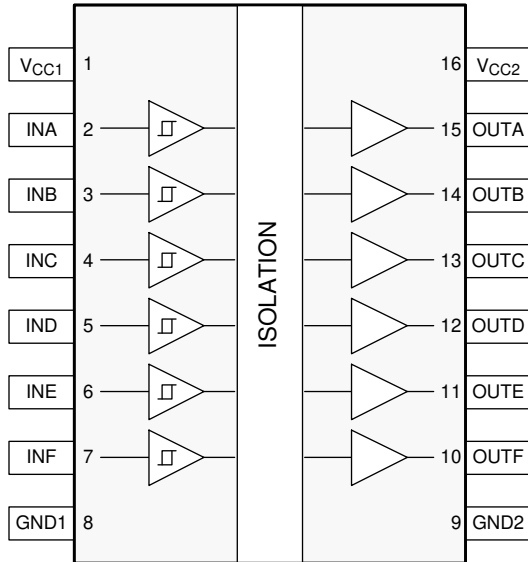

**ISO7761 DW and DBQ Packages
16-Pin SOIC and SSOP
Top View**

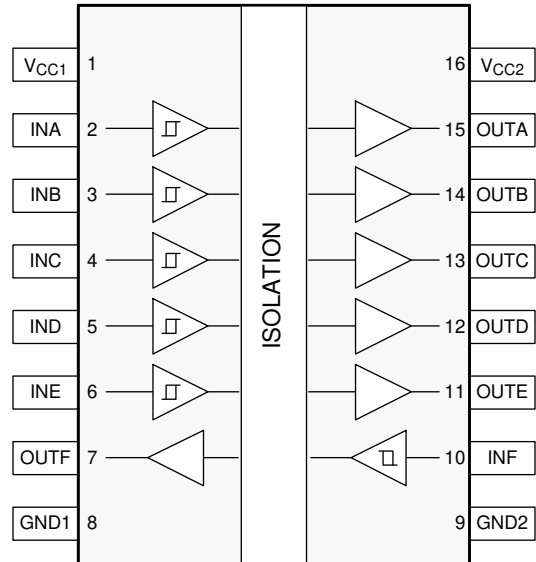

**ISO7762 DW and DBQ Packages
16-Pin SOIC and SSOP
Top View**

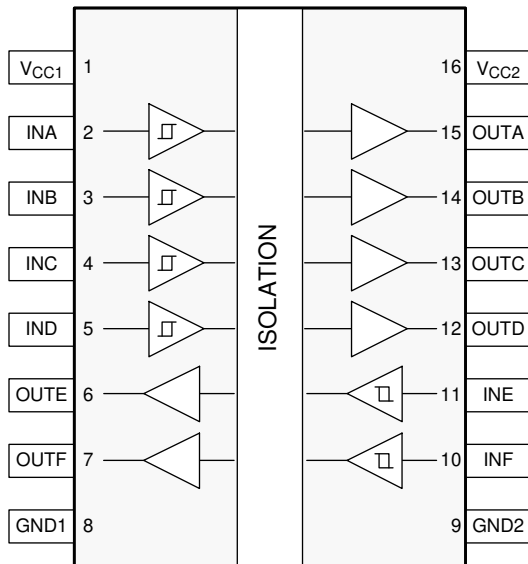

**ISO7763 DW and DBQ Packages
16-Pin SOIC and SSOP
Top View**

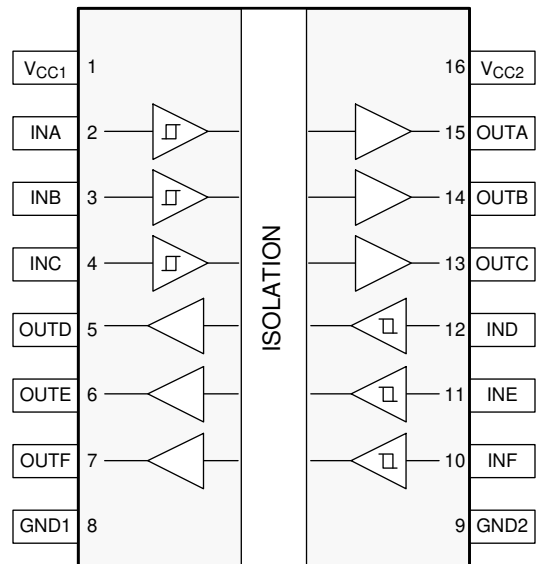

Pin Functions

NAME	PIN				I/O	DESCRIPTION
	NO.					
	ISO7760	ISO7761	ISO7762	ISO7763		
GND1	8	8	8	8	—	Ground connection for V_{CC1}
GND2	9	9	9	9	—	Ground connection for V_{CC2}
INA	2	2	2	2	I	Input, channel A
INB	3	3	3	3	I	Input, channel B
INC	4	4	4	4	I	Input, channel C
IND	5	5	5	12	I	Input, channel D
INE	6	6	11	11	I	Input, channel E
INF	7	10	10	10	I	Input, channel F
OUTA	15	15	15	15	O	Output, channel A
OUTB	14	14	14	14	O	Output, channel B
OUTC	13	13	13	13	O	Output, channel C
OUTD	12	12	12	5	O	Output, channel D
OUTE	11	11	6	6	O	Output, channel E
OUTF	10	7	7	7	O	Output, channel F
V_{CC1}	1	1	1	1	—	Power supply, side 1
V_{CC2}	16	16	16	16	—	Power supply, side 2

6 Specifications

6.1 Absolute Maximum Ratings

See ⁽¹⁾

		MIN	MAX	UNIT
V_{CC1} , V_{CC2}	Supply voltage ⁽²⁾	-0.5	6	V
V	Voltage at INx, OUTx	-0.5	$V_{CCX} + 0.5$ ⁽³⁾	V
I_O	Output current	-15	15	mA
T_J	Junction temperature		150	°C
T_{stg}	Storage temperature	-65	150	°C

- (1) Stresses beyond those listed under *Absolute Maximum Ratings* may cause permanent damage to the device. These are stress ratings only and functional operation of the device at these or any other conditions beyond those indicated under *Recommended Operating Conditions* is not implied. Exposure to absolute-maximum-rated conditions for extended periods may affect device reliability.
- (2) All voltage values except differential I/O bus voltages are with respect to the local ground terminal (GND1 or GND2) and are peak voltage values.
- (3) Maximum voltage must not exceed 6 V

6.2 ESD Ratings

		VALUE	UNIT
$V_{(ESD)}$	Electrostatic discharge	Human body model (HBM), per ANSI/ESDA/JEDEC JS-001 ⁽¹⁾	±6000
		Charged device model (CDM), per JEDEC specification JESD22-C101 ⁽²⁾	±1500
		Contact discharge per IEC 61000-4-2; Isolation barrier withstand test ⁽³⁾⁽⁴⁾	±8000

- (1) JEDEC document JEP155 states that 500-V HBM allows safe manufacturing with a standard ESD control process.
- (2) JEDEC document JEP157 states that 250-V CDM allows safe manufacturing with a standard ESD control process.
- (3) IEC ESD strike is applied across the barrier with all pins on each side tied together creating a two-terminal device.
- (4) Testing is carried out in air or oil to determine the intrinsic contact discharge capability of the device.

6.3 Recommended Operating Conditions

		MIN	NOM	MAX	UNIT
V_{CC1} , V_{CC2}	Supply voltage	2.25		5.5	V
$V_{CC(UVLO+)}$	UVLO threshold when supply voltage is rising		2	2.25	V
$V_{CC(UVLO-)}$	UVLO threshold when supply voltage is falling	1.7	1.8		V
$V_{HYS(UVLO)}$	Supply voltage UVLO hysteresis	100	200		mV
I_{OH}	High-level output current	$V_{CCO}^{(1)} = 5\text{ V}$		-4	mA
		$V_{CCO} = 3.3\text{ V}$		-2	
		$V_{CCO} = 2.5\text{ V}$		-1	
I_{OL}	Low-level output current	$V_{CCO} = 5\text{ V}$		4	mA
		$V_{CCO} = 3.3\text{ V}$		2	
		$V_{CCO} = 2.5\text{ V}$		1	
V_{IH}	High-level input voltage	$0.7 \times V_{CCI}^{(1)}$		V_{CCI}	V
V_{IL}	Low-level input voltage	0		$0.3 \times V_{CCI}$	V
DR ⁽²⁾	Data rate	0		100	Mbps
T_A	Ambient temperature	-55	25	125	°C

- (1) V_{CCI} = Input-side V_{CC} ; V_{CCO} = Output-side V_{CC} .
- (2) 100 Mbps is the maximum specified data rate, although higher data rates are possible.

6.4 Thermal Information

THERMAL METRIC ⁽¹⁾		ISO776x		UNIT
		DW (SOIC)	DBQ (SSOP)	
		16 PINS	16 PINS	
R _{θJA}	Junction-to-ambient thermal resistance	60.3	86.5	°C/W
R _{θJC(top)}	Junction-to-case(top) thermal resistance	24.0	26.9	°C/W
R _{θJB}	Junction-to-board thermal resistance	29.3	36.6	°C/W
ψ _{JT}	Junction-to-top characterization parameter	3.3	1.7	°C/W
ψ _{JB}	Junction-to-board characterization parameter	28.7	36.1	°C/W
R _{θJC(bottom)}	Junction-to-case(bottom) thermal resistance	n/a	n/a	°C/W

(1) For more information about traditional and new thermal metrics, see the [Semiconductor and IC Package Thermal Metrics application report](#).

6.5 Power Ratings

PARAMETER		TEST CONDITIONS	MIN	TYP	MAX	UNIT
ISO7760						
P _D	Maximum power dissipation (both sides)	V _{CC1} = V _{CC2} = 5.5 V, T _J = 150°C, C _L = 15 pF, input a 50-MHz 50% duty cycle square wave			292	mW
P _{D1}	Maximum power dissipation (side 1)	V _{CC1} = V _{CC2} = 5.5 V, T _J = 150°C, C _L = 15 pF, input a 50-MHz 50% duty cycle square wave			50	mW
P _{D2}	Maximum power dissipation (side 2)	V _{CC1} = V _{CC2} = 5.5 V, T _J = 150°C, C _L = 15 pF, input a 50-MHz 50% duty cycle square wave			242	mW
ISO7761						
P _D	Maximum power dissipation (both sides)	V _{CC1} = V _{CC2} = 5.5 V, T _J = 150°C, C _L = 15 pF, input a 50-MHz 50% duty cycle square wave			292	mW
P _{D1}	Maximum power dissipation (side 1)	V _{CC1} = V _{CC2} = 5.5 V, T _J = 150°C, C _L = 15 pF, input a 50-MHz 50% duty cycle square wave			83	mW
P _{D2}	Maximum power dissipation (side 2)	V _{CC1} = V _{CC2} = 5.5 V, T _J = 150°C, C _L = 15 pF, input a 50-MHz 50% duty cycle square wave			209	mW
ISO7762						
P _D	Maximum power dissipation (both sides)	V _{CC1} = V _{CC2} = 5.5 V, T _J = 150°C, C _L = 15 pF, input a 50-MHz 50% duty cycle square wave			292	mW
P _{D1}	Maximum power dissipation (side 1)	V _{CC1} = V _{CC2} = 5.5 V, T _J = 150°C, C _L = 15 pF, input a 50-MHz 50% duty cycle square wave			116	mW
P _{D2}	Maximum power dissipation (side 2)	V _{CC1} = V _{CC2} = 5.5 V, T _J = 150°C, C _L = 15 pF, input a 50-MHz 50% duty cycle square wave			176	mW
ISO7763						
P _D	Maximum power dissipation (both sides)	V _{CC1} = V _{CC2} = 5.5 V, T _J = 150°C, C _L = 15 pF, input a 50-MHz 50% duty cycle square wave			292	mW
P _{D1}	Maximum power dissipation (side 1)	V _{CC1} = V _{CC2} = 5.5 V, T _J = 150°C, C _L = 15 pF, input a 50-MHz 50% duty cycle square wave			146	mW
P _{D2}	Maximum power dissipation (side 2)	V _{CC1} = V _{CC2} = 5.5 V, T _J = 150°C, C _L = 15 pF, input a 50-MHz 50% duty cycle square wave			146	mW

6.6 Insulation Specifications

PARAMETER	TEST CONDITIONS	VALUE		UNIT
		DW-16	DBQ-16	
CLR External clearance ⁽¹⁾	Shortest terminal-to-terminal distance through air	>8	>3.7	mm
CPG External creepage ⁽¹⁾	Shortest terminal-to-terminal distance across the package surface	>8	>3.7	mm
DTI Distance through the insulation	Minimum internal gap (internal clearance)	>21	>21	μm
CTI Tracking resistance (comparative tracking index)	DIN EN 60112 (VDE 0303-11); IEC 60112; UL 746A	>600	>600	V
Material group	According to IEC 60664-1	I	I	
Overvoltage category per IEC 60664-1	Rated mains voltage ≤ 150 V _{RMS}	I-IV	I-IV	
	Rated mains voltage ≤ 300 V _{RMS}	I-IV	I-III	
	Rated mains voltage ≤ 600 V _{RMS}	I-IV	n/a	
	Rated mains voltage ≤ 1000 V _{RMS}	I-III	n/a	
DIN V VDE V 0884-11:2017-01⁽²⁾				
V _{IORM} Maximum repetitive peak isolation voltage	AC voltage (bipolar)	2121	566	V _{PK}
V _{IOWM} Maximum working isolation voltage	AC voltage; Time dependent dielectric breakdown (TDDb) test; see Figure 30	1500	400	V _{RMS}
	DC voltage	2121	566	V _{DC}
V _{IOTM} Maximum transient isolation voltage	V _{TEST} = V _{IOTM} , t = 60 s (qualification) V _{TEST} = 1.2 × V _{IOTM} , t = 1 s (100% production)	ISO7760	8000	V _{PK}
		ISO7761, ISO7762, ISO7763	7071	
V _{IOSM} Maximum surge isolation voltage ⁽³⁾	Test method per IEC 62368-1, 1.2/50 μs waveform, V _{TEST} = 1.6 × V _{IOSM} (qualification)	8000	4000	V _{PK}
q _{pd} Apparent charge ⁽⁴⁾	Method a, After Input/Output safety test subgroup 2/3, V _{ini} = V _{IOTM} , t _{ini} = 60 s; V _{pd(m)} = 1.2 × V _{IORM} , t _m = 10 s	≤5	≤5	pC
	Method a, After environmental tests subgroup 1, V _{ini} = V _{IOTM} , t _{ini} = 60 s; V _{pd(m)} = 1.6 × V _{IORM} , t _m = 10 s	≤5	≤5	
	Method b1; At routine test (100% production) and preconditioning (type test) V _{ini} = 1.2 × V _{IOTM} , t _{ini} = 1 s; V _{pd(m)} = 1.875 × V _{IORM} , t _m = 1 s	≤5	≤5	
C _{IO} Barrier capacitance, input to output ⁽⁵⁾	V _{IO} = 0.4 × sin(2πft), f = 1 MHz	~1.1	~0.9	pF
R _{IO} Isolation resistance ⁽⁵⁾	V _{IO} = 500 V, T _A = 25°C	>10 ¹²	>10 ¹²	Ω
	V _{IO} = 500 V, 100°C ≤ T _A ≤ 125°C	>10 ¹¹	>10 ¹¹	
	V _{IO} = 500 V, T _S = 150°C	>10 ⁹	>10 ⁹	
Pollution degree		2	2	
Climatic category		55/125/21	55/125/21	
UL 1577				
V _{ISO} Withstanding isolation voltage	V _{TEST} = V _{ISO} , t = 60 s (qualification), V _{TEST} = 1.2 × V _{ISO} , t = 1 s (100% production)	5000	3000	V _{RMS}

- (1) Creepage and clearance requirements should be applied according to the specific equipment isolation standards of an application. Care should be taken to maintain the creepage and clearance distance of a board design to ensure that the mounting pads of the isolator on the printed-circuit board do not reduce this distance. Creepage and clearance on a printed-circuit board become equal in certain cases. Techniques such as inserting grooves and/or ribs on a printed circuit board are used to help increase these specifications.
- (2) This coupler is suitable for *safe electrical insulation only* within the safety ratings. Compliance with the safety ratings shall be ensured by means of suitable protective circuits
- (3) Testing is carried out in air or oil to determine the intrinsic surge immunity of the isolation barrier.
- (4) Apparent charge is electrical discharge caused by a partial discharge (pd).
- (5) All pins on each side of the barrier tied together creating a two-terminal device.

6.7 Safety-Related Certifications

VDE	CSA	UL	CQC	TUV
Certified according to DIN V VDE V 0884-11:2017-01	Certified according to IEC 60950-1, IEC 62368-1 and IEC 60601-1	Recognized under UL 1577 Component Recognition Program	Certified according to GB 4943.1-2011	Certified according to EN 61010-1:2010 (3rd Ed) and EN 60950-1:2006/A2:2013
Reinforced Insulation; Maximum transient isolation voltage, 8000 V _{PK} (ISO7760 in DW-16), 7071 V _{PK} (ISO7761, ISO7762, ISO7763 in DW-16) and 4242 V _{PK} (DBQ-16); Maximum repetitive peak isolation voltage, 2121 V _{PK} (DW-16) and 566 V _{PK} (DBQ-16); Maximum surge isolation voltage, 8000 V _{PK} (DW-16) and 4000 V _{PK} (DBQ-16)	Reinforced insulation per CSA 60950-1-07+A1+A2, IEC 60950-1 2nd Ed.+A1+A2, CSA 62368-1-14 and IEC 62368-1:2014 800 V _{RMS} (DW-16) and 370 V _{RMS} (DBQ-16) maximum working voltage (pollution degree 2, material group I); DW-16: 2 MOPP (Means of Patient Protection) per CSA 60601-1:14 and IEC 60601-1 Ed. 3.1, 250 V _{RMS} maximum working voltage	DW-16: Single protection, 5000 V _{RMS} ; DBQ-16: Single protection, 3000 V _{RMS}	DW-16: Reinforced Insulation, Altitude ≤ 5000 m, Tropical Climate, 400 V _{RMS} maximum working voltage; DBQ-16: Basic Insulation, Altitude ≤ 5000 m, Tropical Climate, 250 V _{RMS} maximum working voltage	5000 V _{RMS} Reinforced insulation per EN 61010-1:2010 (3rd Ed) up to working voltage of 600 V _{RMS} (DW-16) and 300 V _{RMS} (DBQ-16) 5000 V _{RMS} Reinforced insulation per EN 60950-1:2006/A2:2013 up to working voltage of 800 V _{RMS} (DW-16) and 370 V _{RMS} (DBQ-16)
Certificate number: 40040142	Master contract number: 220991	File number: E181974	Certificate number: CQC15001121716 (DW) Certificate number: CQC18001199097 (DBQ)	Client ID number: 77311

6.8 Safety Limiting Values

Safety limiting intends to minimize potential damage to the isolation barrier upon failure of input or output circuitry.

PARAMETER		TEST CONDITIONS	MIN	TYP	MAX	UNIT
DW-16 PACKAGE						
I _S	Safety input, output, or supply current ⁽¹⁾	R _{θJA} = 60.3 °C/W, V _I = 5.5 V, T _J = 150°C, T _A = 25°C, see Figure 1			377	mA
		R _{θJA} = 60.3 °C/W, V _I = 3.6 V, T _J = 150°C, T _A = 25°C, see Figure 1			576	
		R _{θJA} = 60.3 °C/W, V _I = 2.75 V, T _J = 150°C, T _A = 25°C, see Figure 1			754	
P _S	Safety input, output, or total power ⁽¹⁾	R _{θJA} = 60.3 °C/W, T _J = 150°C, T _A = 25°C, see Figure 3			2073	mW
T _S	Maximum safety temperature ⁽¹⁾				150	°C
DBQ-16 PACKAGE						
I _S	Safety input, output, or supply current ⁽¹⁾	R _{θJA} = 86.5 °C/W, V _I = 5.5 V, T _J = 150°C, T _A = 25°C, see Figure 2			263	mA
		R _{θJA} = 86.5 °C/W, V _I = 3.6 V, T _J = 150°C, T _A = 25°C, see Figure 2			401	
		R _{θJA} = 86.5 °C/W, V _I = 2.75 V, T _J = 150°C, T _A = 25°C, see Figure 2			525	
P _S	Safety input, output, or total power ⁽¹⁾	R _{θJA} = 86.5 °C/W, T _J = 150°C, T _A = 25°C, see Figure 4			1445	mW
T _S	Maximum safety temperature ⁽¹⁾				150	°C

- (1) The maximum safety temperature, T_S, has the same value as the maximum junction temperature, T_J, specified for the device. The I_S and P_S parameters represent the safety current and safety power respectively. The maximum limits of I_S and P_S should not be exceeded. These limits vary with the ambient temperature, T_A.

The junction-to-air thermal resistance, R_{θJA}, in the [Thermal Information](#) table is that of a device installed on a high-K test board for leaded surface-mount packages. Use these equations to calculate the value for each parameter:

$$T_J = T_A + R_{\theta JA} \times P, \text{ where } P \text{ is the power dissipated in the device.}$$

$$T_{J(max)} = T_S = T_A + R_{\theta JA} \times P_S, \text{ where } T_{J(max)} \text{ is the maximum allowed junction temperature.}$$

$$P_S = I_S \times V_I, \text{ where } V_I \text{ is the maximum input voltage.}$$

6.9 Electrical Characteristics—5-V Supply

$V_{CC1} = V_{CC2} = 5\text{ V} \pm 10\%$ (over recommended operating conditions unless otherwise noted)

PARAMETER		TEST CONDITIONS	MIN	TYP	MAX	UNIT
V_{OH}	High-level output voltage	$I_{OH} = -4\text{ mA}$; see Figure 18	$V_{CCO}^{(1)} - 0.4$	4.8		V
V_{OL}	Low-level output voltage	$I_{OL} = 4\text{ mA}$; see Figure 18		0.2	0.4	V
$V_{IT+(IN)}$	Rising input threshold voltage			$0.6 \times V_{CCI}$	$0.7 \times V_{CCI}$	V
$V_{IT-(IN)}$	Falling input threshold voltage		$0.3 \times V_{CCI}$	$0.4 \times V_{CCI}$		V
$V_{I(HYS)}$	Input threshold voltage hysteresis		$0.1 \times V_{CCI}$	$0.2 \times V_{CCI}$		V
I_{IH}	High-level input current	$V_{IH} = V_{CCI}^{(1)}$ at INx			10	μA
I_{IL}	Low-level input current	$V_{IL} = 0\text{ V}$ at INx	-10			μA
CMTI	Common-mode transient immunity	$V_I = V_{CCI}$ or 0 V , $V_{CM} = 1200\text{ V}$; see Figure 20	85	100		$\text{kV}/\mu\text{s}$
C_I	Input capacitance ⁽²⁾	$V_I = V_{CC} / 2 + 0.4 \times \sin(2\pi ft)$, $f = 1\text{ MHz}$, $V_{CC} = 5\text{ V}$		2		pF

(1) V_{CCI} = Input-side V_{CC} ; V_{CCO} = Output-side V_{CC} .

(2) Measured from input pin to ground.

6.10 Supply Current Characteristics—5-V Supply

 $V_{CC1} = V_{CC2} = 5\text{ V} \pm 10\%$ (over recommended operating conditions unless otherwise noted).

PARAMETER	TEST CONDITIONS	SUPPLY CURRENT	MIN	TYP	MAX	UNIT	
ISO7760							
Supply current - DC signal	$V_I = V_{CC1}$ (ISO7760); $V_I = 0\text{ V}$ (ISO7760 with F suffix)	I_{CC1}		1.6	2.3	mA	
		I_{CC2}		3	4.9		
	$V_I = 0\text{ V}$ (ISO7760); $V_I = V_{CC1}$ (ISO7760 with F suffix)	I_{CC1}		8	11.3		
		I_{CC2}		3.3	5.3		
Supply current - AC signal	All channels switching with square wave clock input; $C_L = 15\text{ pF}$	1 Mbps	I_{CC1}		5	6.4	mA
			I_{CC2}		3.5	5.6	
		10 Mbps	I_{CC1}		5.2	6.7	
			I_{CC2}		6.4	9	
		100 Mbps	I_{CC1}		7	9	
			I_{CC2}		35	44	
ISO7761							
Supply current - DC signal	$V_I = V_{CCI}^{(1)}$ (ISO7761); $V_I = 0\text{ V}$ (ISO7761 with F suffix)	I_{CC1}		1.9	2.7	mA	
		I_{CC2}		2.9	4.7		
	$V_I = 0\text{ V}$ (ISO7761); $V_I = V_{CCI}$ (ISO7761 with F suffix)	I_{CC1}		7.3	10.6		
		I_{CC2}		4.2	6.6		
Supply current - AC signal	All channels switching with square wave clock input; $C_L = 15\text{ pF}$	1 Mbps	I_{CC1}		4.7	6.4	mA
			I_{CC2}		3.8	5.9	
		10 Mbps	I_{CC1}		5.3	7.2	
			I_{CC2}		6.3	8.8	
		100 Mbps	I_{CC1}		11.5	15	
			I_{CC2}		30.5	38	
ISO7762							
Supply current - DC signal	$V_I = V_{CCI}$ (ISO7762); $V_I = 0\text{ V}$ (ISO7762 with F suffix)	I_{CC1}		2.1	3.2	mA	
		I_{CC2}		2.6	4.2		
	$V_I = 0\text{ V}$ (ISO7762); $V_I = V_{CCI}$ (ISO7762 with F suffix)	I_{CC1}		6.5	9.3		
		I_{CC2}		5	7.5		
Supply current - AC signal	All channels switching with square wave clock input; $C_L = 15\text{ pF}$	1 Mbps	I_{CC1}		4.5	6.3	mA
			I_{CC2}		4	6.1	
		10 Mbps	I_{CC1}		5.6	7.6	
			I_{CC2}		6	8.4	
		100 Mbps	I_{CC1}		16.5	21	
			I_{CC2}		25.7	32	
ISO7763							
Supply current - DC signal	$V_I = V_{CCI}$ (ISO7763); $V_I = 0\text{ V}$ (ISO7763 with F suffix)	I_{CC1}, I_{CC2}		2.4	3.7	mA	
	$V_I = 0\text{ V}$ (ISO7763); $V_I = V_{CCI}$ (ISO7763 with F suffix)	I_{CC1}, I_{CC2}		5.7	8.6		
Supply current - AC signal	All channels switching with square wave clock input; $C_L = 15\text{ pF}$	1 Mbps	I_{CC1}, I_{CC2}		4.2	6.1	mA
		10 Mbps	I_{CC1}, I_{CC2}		5.8	8	
		100 Mbps	I_{CC1}, I_{CC2}		21	26.5	

(1) $V_{CCI} = \text{Input-side } V_{CC}$

6.11 Electrical Characteristics—3.3-V Supply

$V_{CC1} = V_{CC2} = 3.3 \text{ V} \pm 10\%$ (over recommended operating conditions unless otherwise noted)

PARAMETER		TEST CONDITIONS	MIN	TYP	MAX	UNIT
V_{OH}	High-level output voltage	$I_{OH} = -2 \text{ mA}$; see Figure 18	$V_{CCO}^{(1)} - 0.3$	3.2		V
V_{OL}	Low-level output voltage	$I_{OL} = 2 \text{ mA}$; see Figure 18		0.1	0.3	V
$V_{IT+(IN)}$	Rising input threshold voltage			$0.6 \times V_{CCI}$	$0.7 \times V_{CCI}$	V
$V_{IT-(IN)}$	Falling input threshold voltage		$0.3 \times V_{CCI}$	$0.4 \times V_{CCI}$		V
$V_{I(HYS)}$	Input threshold voltage hysteresis		$0.1 \times V_{CCI}$	$0.2 \times V_{CCI}$		V
I_{IH}	High-level input current	$V_{CCI(H)} = V^{(1)}$ at INx			10	μA
I_{IL}	Low-level input current	$V_{IL} = 0 \text{ V}$ at INx	-10			μA
CMTI	Common-mode transient immunity	$V_I = V_{CCI}$ or 0 V , $V_{CM} = 1200 \text{ V}$; see Figure 20	85	100		$\text{kV}/\mu\text{s}$

(1) V_{CCI} = Input-side V_{CC} ; V_{CCO} = Output-side V_{CC} .

6.12 Supply Current Characteristics—3.3-V Supply

 $V_{CC1} = V_{CC2} = 3.3\text{ V} \pm 10\%$ (over recommended operating conditions unless otherwise noted).

PARAMETER	TEST CONDITIONS	SUPPLY CURRENT	MIN	TYP	MAX	UNIT	
ISO7760							
Supply current - DC signal	$V_I = V_{CC1}$ (ISO7760); $V_I = 0\text{ V}$ (ISO7760 with F suffix)	I_{CC1}		1.6	2.2	mA	
		I_{CC2}		3	4.8		
	$V_I = 0\text{ V}$ (ISO7760); $V_I = V_{CC1}$ (ISO7760 with F suffix)	I_{CC1}		8	11.4		
		I_{CC2}		3.3	5.3		
Supply current - AC signal	All channels switching with square wave clock input; $C_L = 15\text{ pF}$	1 Mbps	I_{CC1}		4.9	6.6	mA
			I_{CC2}		3.4	5.3	
		10 Mbps	I_{CC1}		5	6.7	
			I_{CC2}		5.5	7.8	
		100 Mbps	I_{CC1}		6.3	8.2	
			I_{CC2}		26	33	
ISO7761							
Supply current - DC signal	$V_I = V_{CCI}^{(1)}$ (ISO7761); $V_I = 0\text{ V}$ (ISO7761 with F suffix)	I_{CC1}		1.8	2.7	mA	
		I_{CC2}		2.9	4.7		
	$V_I = 0\text{ V}$ (ISO7761); $V_I = V_{CCI}$ (ISO7761 with F suffix)	I_{CC1}		7.2	10.3		
		I_{CC2}		4.2	6.6		
Supply current - AC signal	All channels switching with square wave clock input; $C_L = 15\text{ pF}$	1 Mbps	I_{CC1}		4.6	6.5	mA
			I_{CC2}		3.7	5.7	
		10 Mbps	I_{CC1}		5.1	7	
			I_{CC2}		5.5	7.8	
		100 Mbps	I_{CC1}		9.4	12	
			I_{CC2}		22.8	29	
ISO7762							
Supply current - DC signal	$V_I = V_{CCI}$ (ISO7762); $V_I = 0\text{ V}$ (ISO7762 with F suffix)	I_{CC1}		2.1	3.2	mA	
		I_{CC2}		2.5	4.2		
	$V_I = 0\text{ V}$ (ISO7762); $V_I = V_{CCI}$ (ISO7762 with F suffix)	I_{CC1}		6.5	9.4		
		I_{CC2}		5	7.5		
Supply current - AC signal	All channels switching with square wave clock input; $C_L = 15\text{ pF}$	1 Mbps	I_{CC1}		4.4	6.2	mA
			I_{CC2}		3.9	5.8	
		10 Mbps	I_{CC1}		5.2	7.1	
			I_{CC2}		5.4	7.5	
		100 Mbps	I_{CC1}		12.9	16.5	
			I_{CC2}		19.5	25	
ISO7763							
Supply current - DC signal	$V_I = V_{CCI}$ (ISO7763); $V_I = 0\text{ V}$ (ISO7763 with F suffix)	I_{CC1}, I_{CC2}		2.4	3.7	mA	
	$V_I = 0\text{ V}$ (ISO7763); $V_I = V_{CCI}$ (ISO7763 with F suffix)	I_{CC1}, I_{CC2}		5.7	8.4		
Supply current - AC signal	All channels switching with square wave clock input; $C_L = 15\text{ pF}$	1 Mbps	I_{CC1}, I_{CC2}		4.2	6.2	mA
		10 Mbps	I_{CC1}, I_{CC2}		5.2	7.5	
		100 Mbps	I_{CC1}, I_{CC2}		16	20.5	

(1) $V_{CCI} = \text{Input-side } V_{CC}$

6.13 Electrical Characteristics—2.5-V Supply

$V_{CC1} = V_{CC2} = 2.5 \text{ V} \pm 10\%$ (over recommended operating conditions unless otherwise noted)

PARAMETER		TEST CONDITIONS	MIN	TYP	MAX	UNIT
V_{OH}	High-level output voltage	$I_{OH} = -1 \text{ mA}$; see Figure 18	$V_{CCO}^{(1)} - 0.2$	2.45		V
V_{OL}	Low-level output voltage	$I_{OL} = 1 \text{ mA}$; see Figure 18		0.05	0.2	V
$V_{IT+(IN)}$	Rising input threshold voltage			$0.6 \times V_{CCI}$	$0.7 \times V_{CCI}$	V
$V_{IT-(IN)}$	Falling input threshold voltage		$0.3 \times V_{CCI}$	$0.4 \times V_{CCI}$		V
$V_{I(HYS)}$	Input threshold voltage hysteresis		$0.1 \times V_{CCI}$	$0.2 \times V_{CCI}$		V
I_{IH}	High-level input current	$V_{IH} = V_{CCI}^{(1)}$ at INx			10	μA
I_{IL}	Low-level input current	$V_{IL} = 0 \text{ V}$ at INx	-10			μA
CMTI	Common-mode transient immunity	$V_I = V_{CCI}$ or 0 V , $V_{CM} = 1200 \text{ V}$; see Figure 20	85	100		$\text{kV}/\mu\text{s}$

(1) V_{CCI} = Input-side V_{CC} ; V_{CCO} = Output-side V_{CC} .

6.14 Supply Current Characteristics—2.5-V Supply

 $V_{CC1} = V_{CC2} = 2.5\text{ V} \pm 10\%$ (over recommended operating conditions unless otherwise noted).

PARAMETER	TEST CONDITIONS	SUPPLY CURRENT	MIN	TYP	MAX	UNIT	
ISO7760							
Supply current - DC signal	$V_I = V_{CC1}$ (ISO7760); $V_I = 0\text{ V}$ (ISO7760 with F suffix)	I_{CC1}		1.6	2.2	mA	
		I_{CC2}		3	4.8		
	$V_I = 0\text{ V}$ (ISO7760); $V_I = V_{CC1}$ (ISO7760 with F suffix)	I_{CC1}		8	11.6		
		I_{CC2}		3.3	5.3		
Supply current - AC signal	All channels switching with square wave clock input; $C_L = 15\text{ pF}$	1 Mbps	I_{CC1}		4.9	6.8	mA
			I_{CC2}		3.4	5.3	
		10 Mbps	I_{CC1}		5	7	
			I_{CC2}		4.9	7.2	
		100 Mbps	I_{CC1}		6	8	
			I_{CC2}		20.3	26	
ISO7761							
Supply current - DC signal	$V_I = V_{CCI}^{(1)}$ (ISO7761); $V_I = 0\text{ V}$ (ISO7761 with F suffix)	I_{CC1}		1.8	2.7	mA	
		I_{CC2}		2.9	4.6		
	$V_I = 0\text{ V}$ (ISO7761); $V_I = V_{CCI}$ (ISO7761 with F suffix)	I_{CC1}		7.2	10.3		
		I_{CC2}		4.2	6.5		
Supply current - AC signal	All channels switching with square wave clock input; $C_L = 15\text{ pF}$	1 Mbps	I_{CC1}		4.6	6.7	mA
			I_{CC2}		3.7	5.8	
		10 Mbps	I_{CC1}		4.9	7.1	
			I_{CC2}		5	7.3	
		100 Mbps	I_{CC1}		8.3	10.7	
			I_{CC2}		18.1	24	
ISO7762							
Supply current - DC signal	$V_I = V_{CCI}$ (ISO7762); $V_I = 0\text{ V}$ (ISO7762 with F suffix)	I_{CC1}		2.1	3.2	mA	
		I_{CC2}		2.6	4.1		
	$V_I = 0\text{ V}$ (ISO7762); $V_I = V_{CCI}$ (ISO7762 with F suffix)	I_{CC1}		6.5	9.6		
		I_{CC2}		4.9	7.5		
Supply current - AC signal	All channels switching with square wave clock input; $C_L = 15\text{ pF}$	1 Mbps	I_{CC1}		4.4	6.4	mA
			I_{CC2}		3.9	5.8	
		10 Mbps	I_{CC1}		5	7.1	
			I_{CC2}		5	7.1	
		100 Mbps	I_{CC1}		10.9	14.1	
			I_{CC2}		15.6	20.1	
ISO7763							
Supply current - DC signal	$V_I = V_{CCI}$ (ISO7763); $V_I = 0\text{ V}$ (ISO7763 with F suffix)	I_{CC1}, I_{CC2}		2.3	3.7	mA	
	$V_I = 0\text{ V}$ (ISO7763); $V_I = V_{CCI}$ (ISO7763 with F suffix)	I_{CC1}, I_{CC2}		5.7	8.4		
Supply current - AC signal	All channels switching with square wave clock input; $C_L = 15\text{ pF}$	1 Mbps	I_{CC1}, I_{CC2}		4.1	6.1	mA
		10 Mbps	I_{CC1}, I_{CC2}		4.9	7.1	
		100 Mbps	I_{CC1}, I_{CC2}		13	17	

(1) $V_{CCI} = \text{Input-side } V_{CC}$

6.15 Switching Characteristics—5-V Supply

$V_{CC1} = V_{CC2} = 5\text{ V} \pm 10\%$ (over recommended operating conditions unless otherwise noted)

PARAMETER	TEST CONDITIONS	MIN	TYP	MAX	UNIT
t_{PLH} , t_{PHL} Propagation delay time	See Figure 18	6	11	16	ns
PWD Pulse width distortion ⁽¹⁾ $ t_{PHL} - t_{PLH} $					
$t_{sk(o)}$ Channel-to-channel output skew time ⁽²⁾	Same-direction channels			4	ns
$t_{sk(pp)}$ Part-to-part skew time ⁽³⁾				4.5	ns
t_r Output signal rise time	See Figure 18		1.1	3.9	ns
t_f Output signal fall time					
t_{DO} Default output delay time from input power loss	Measured from the time V_{CC} goes below 1.7 V. See Figure 19		0.2	0.3	μs
t_{ie} Time interval error	$2^{16} - 1$ PRBS data at 100 Mbps		1.3		ns

- (1) Also known as pulse skew.
- (2) $t_{sk(o)}$ is the skew between outputs of a single device with all driving inputs connected together and the outputs switching in the same direction while driving identical loads.
- (3) $t_{sk(pp)}$ is the magnitude of the difference in propagation delay times between any terminals of different devices switching in the same direction while operating at identical supply voltages, temperature, input signals and loads.

6.16 Switching Characteristics—3.3-V Supply

$V_{CC1} = V_{CC2} = 3.3\text{ V} \pm 10\%$ (over recommended operating conditions unless otherwise noted)

PARAMETER	TEST CONDITIONS	MIN	TYP	MAX	UNIT
t_{PLH} , t_{PHL} Propagation delay time	See Figure 18	6	12	16	ns
PWD Pulse width distortion ⁽¹⁾ $ t_{PHL} - t_{PLH} $					
$t_{sk(o)}$ Channel-to-channel output skew time ⁽²⁾	Same-direction channels			4.1	ns
$t_{sk(pp)}$ Part-to-part skew time ⁽³⁾				4.5	ns
t_r Output signal rise time	See Figure 18		1	3	ns
t_f Output signal fall time					
t_{DO} Default output delay time from input power loss	Measured from the time V_{CC} goes below 1.7 V. See Figure 19		0.2	0.3	μs
t_{ie} Time interval error	$2^{16} - 1$ PRBS data at 100 Mbps		1.3		ns

- (1) Also known as pulse skew.
- (2) $t_{sk(o)}$ is the skew between outputs of a single device with all driving inputs connected together and the outputs switching in the same direction while driving identical loads.
- (3) $t_{sk(pp)}$ is the magnitude of the difference in propagation delay times between any terminals of different devices switching in the same direction while operating at identical supply voltages, temperature, input signals and loads.

6.17 Switching Characteristics—2.5-V Supply

$V_{CC1} = V_{CC2} = 2.5\text{ V} \pm 10\%$ (over recommended operating conditions unless otherwise noted)

PARAMETER	TEST CONDITIONS	MIN	TYP	MAX	UNIT
t_{PLH} , t_{PHL} Propagation delay time	See Figure 18	7.5	13	18.5	ns
PWD Pulse width distortion ⁽¹⁾ $ t_{PHL} - t_{PLH} $			0.6	5.1	ns
$t_{sk(o)}$ Channel-to-channel output skew time ⁽²⁾	Same-direction channels			4.1	ns
$t_{sk(pp)}$ Part-to-part skew time ⁽³⁾				4.6	ns
t_r Output signal rise time	See Figure 18		1	3.5	ns
t_f Output signal fall time				1	3.5
t_{DO} Default output delay time from input power loss	Measured from the time V_{CC} goes below 1.7 V. See Figure 19		0.1	0.3	μ s
t_{ie} Time interval error	$2^{16} - 1$ PRBS data at 100 Mbps		1.3		ns

- (1) Also known as pulse skew.
- (2) $t_{sk(o)}$ is the skew between outputs of a single device with all driving inputs connected together and the outputs switching in the same direction while driving identical loads.
- (3) $t_{sk(pp)}$ is the magnitude of the difference in propagation delay times between any terminals of different devices switching in the same direction while operating at identical supply voltages, temperature, input signals and loads.

6.18 Insulation Characteristics Curves

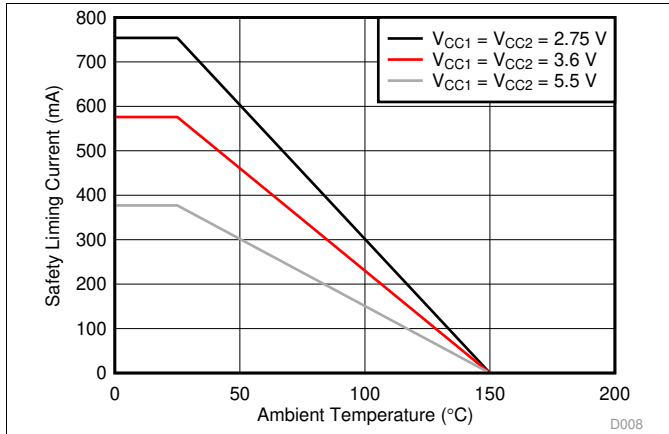

Figure 1. Thermal Derating Curve for Limiting Current per VDE for DW-16 Package

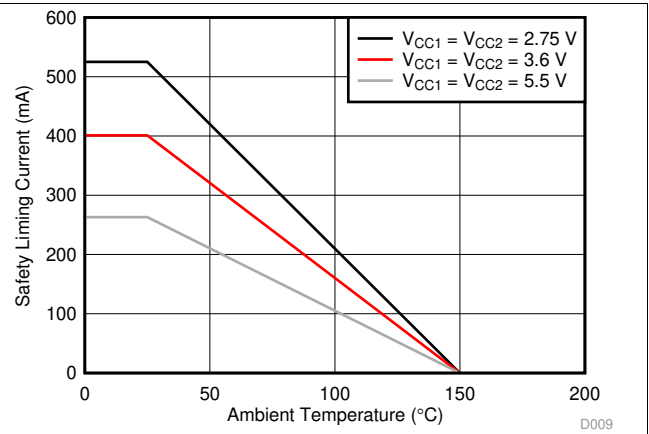

Figure 2. Thermal Derating Curve for Limiting Current per VDE for DBQ-16 Package

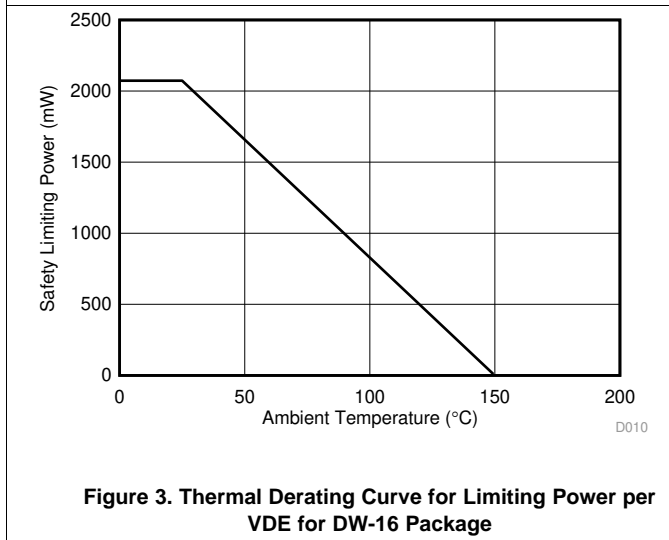

Figure 3. Thermal Derating Curve for Limiting Power per VDE for DW-16 Package

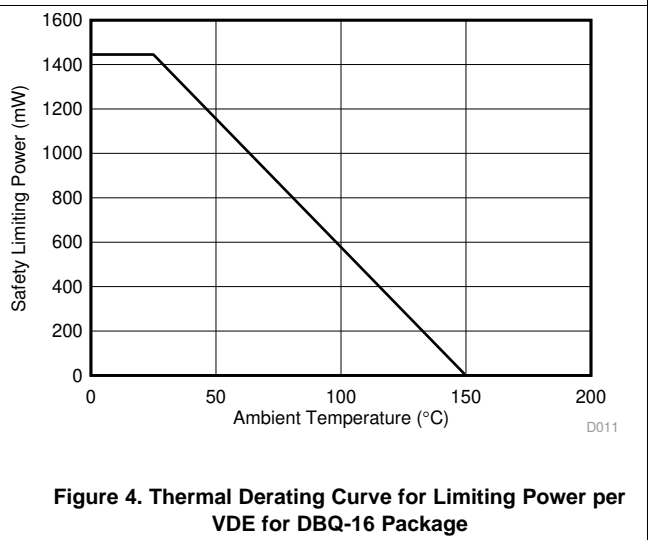

Figure 4. Thermal Derating Curve for Limiting Power per VDE for DBQ-16 Package

6.19 Typical Characteristics

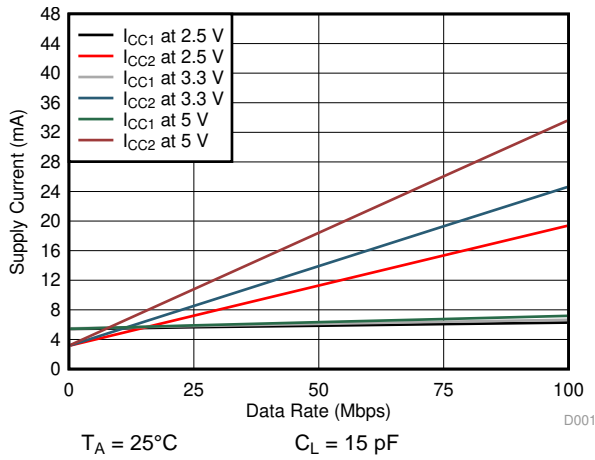

Figure 5. ISO7760 Supply Current vs Data Rate (With 15-pF Load)

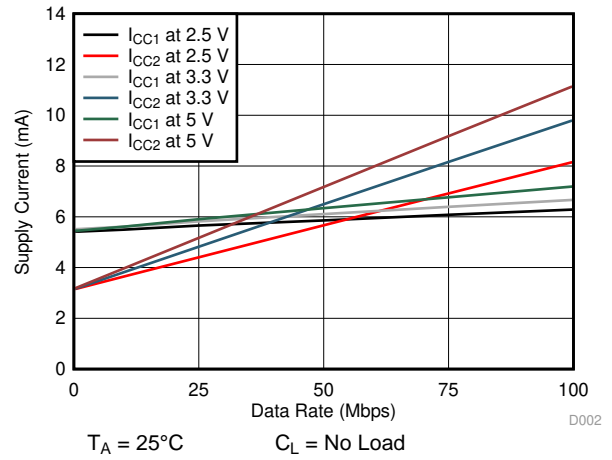

Figure 6. ISO7760 Supply Current vs Data Rate (With No Load)

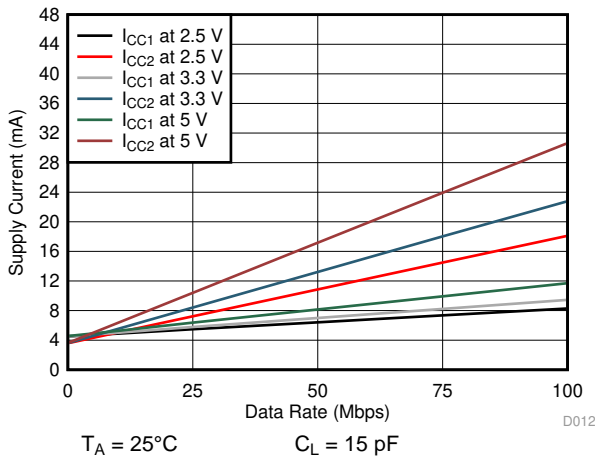

Figure 7. ISO7761 Supply Current vs Data Rate (With 15-pF Load)

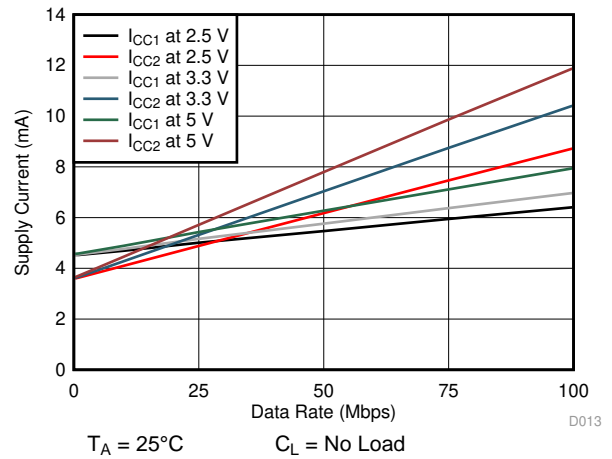

Figure 8. ISO7761 Supply Current vs Data Rate (With No Load)

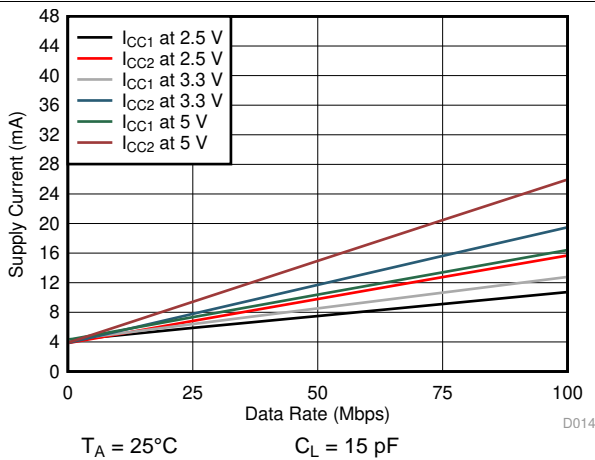

Figure 9. ISO7762 Supply Current vs Data Rate (With 15-pF Load)

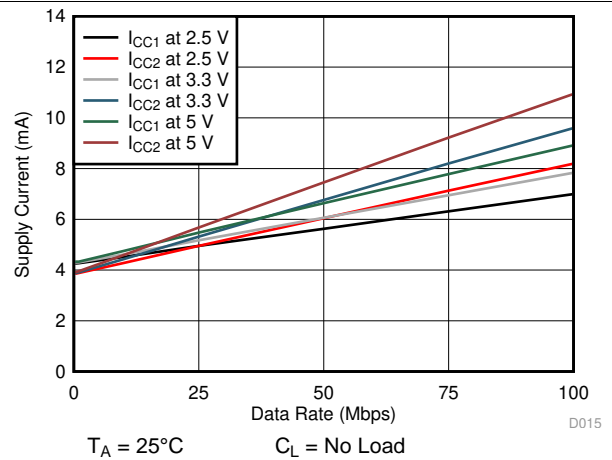

Figure 10. ISO7762 Supply Current vs Data Rate (With No Load)

Typical Characteristics (continued)

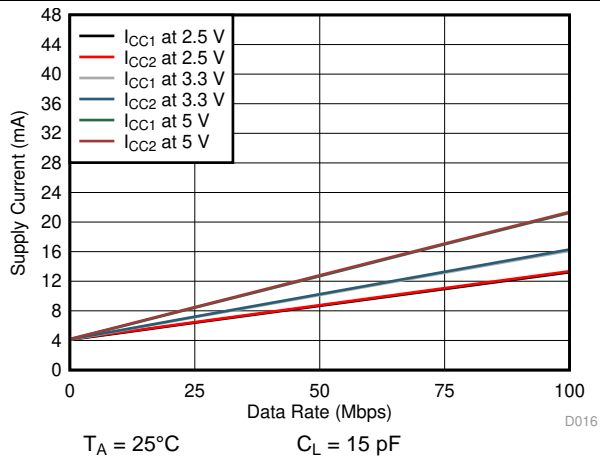

Figure 11. ISO7763 Supply Current vs Data Rate (With 15-pF Load)

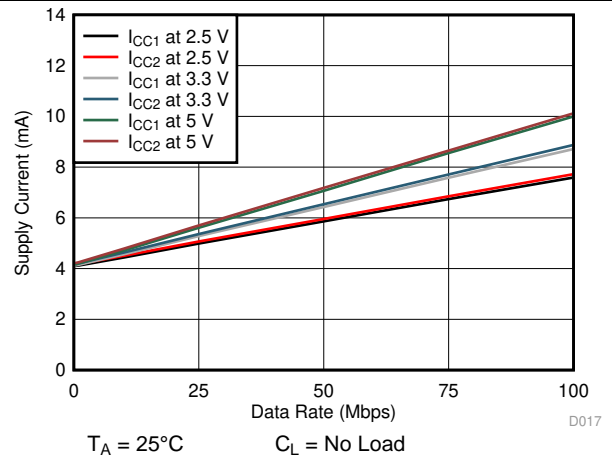

Figure 12. ISO7763 Supply Current vs Data Rate (With No Load)

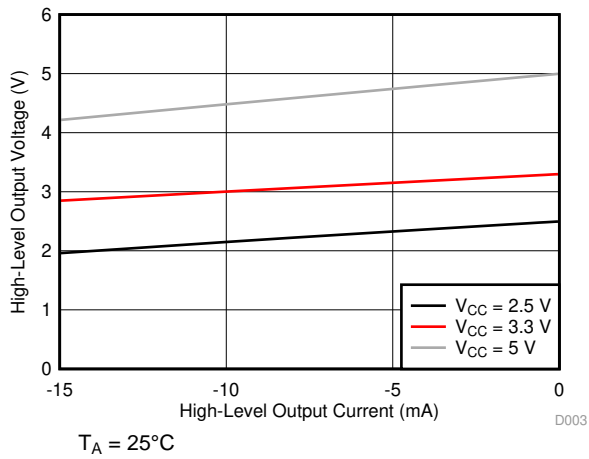

Figure 13. High-Level Output Voltage vs High-Level Output Current

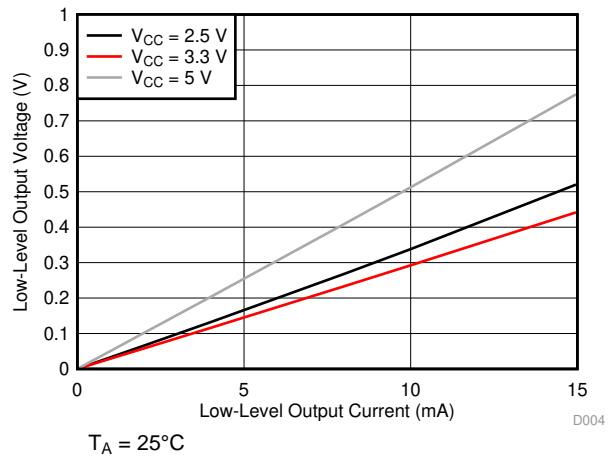

Figure 14. Low-Level Output Voltage vs Low-Level Output Current

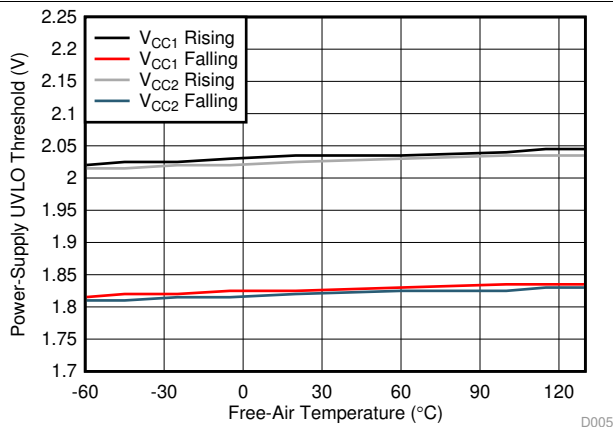

Figure 15. Power Supply Undervoltage Threshold vs Free-Air Temperature

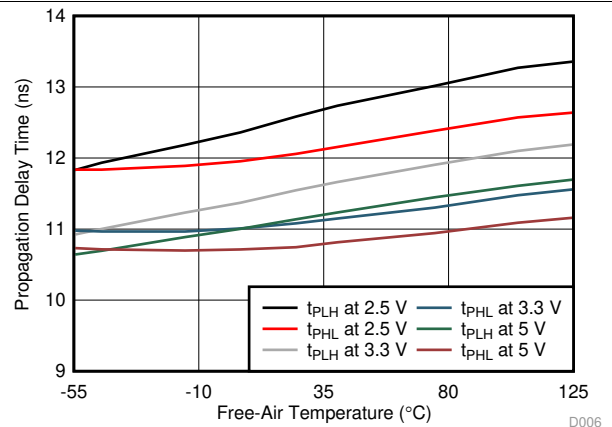
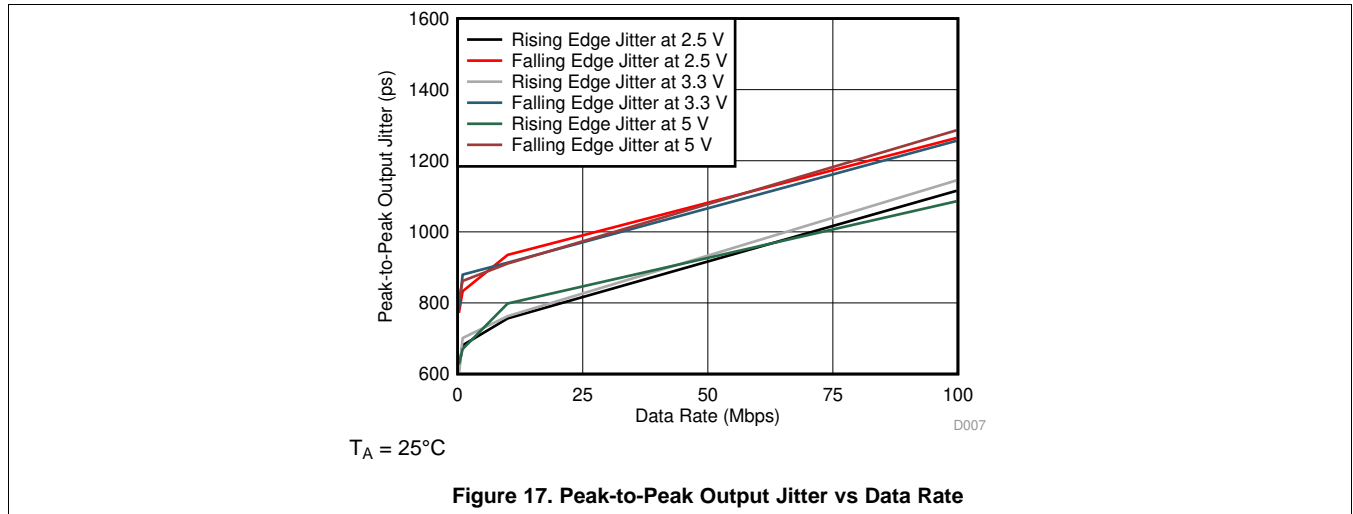
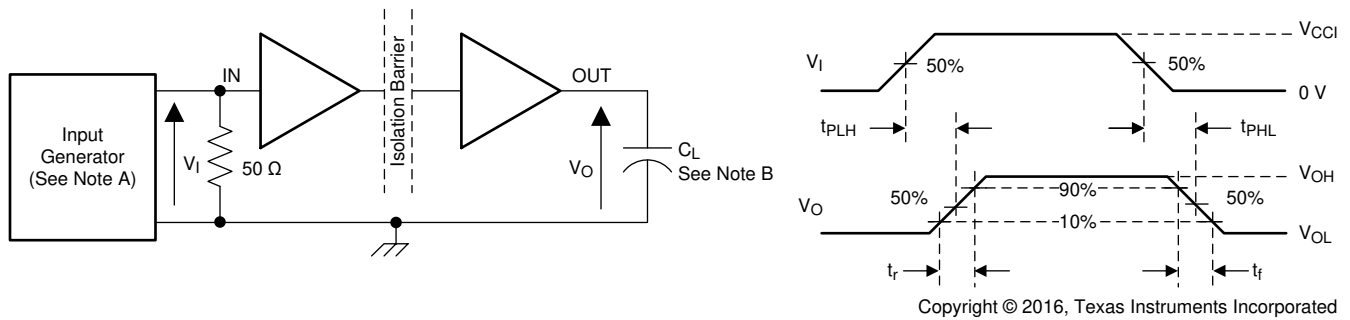

Figure 16. Propagation Delay Time vs Free-Air Temperature

Typical Characteristics (continued)



7 Parameter Measurement Information



- A. The input pulse is supplied by a generator having the following characteristics: PRR \leq 50 kHz, 50% duty cycle, $t_r \leq 3$ ns, $t_f \leq 3$ ns, $Z_O = 50 \Omega$. At the input, a 50- Ω resistor is required to terminate Input Generator signal. It is not needed in actual application.
- B. $C_L = 15$ pF and includes instrumentation and fixture capacitance within $\pm 20\%$.

Figure 18. Switching Characteristics Test Circuit and Voltage Waveforms

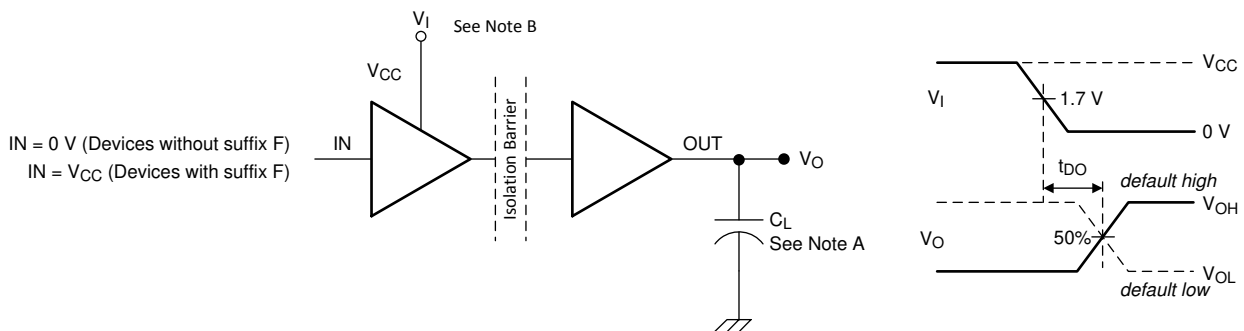

- A. $C_L = 15$ pF and includes instrumentation and fixture capacitance within $\pm 20\%$.
- B. Power-supply ramp rate = 10 mV/ns

Figure 19. Default Output Delay Time Test Circuit and Voltage Waveforms

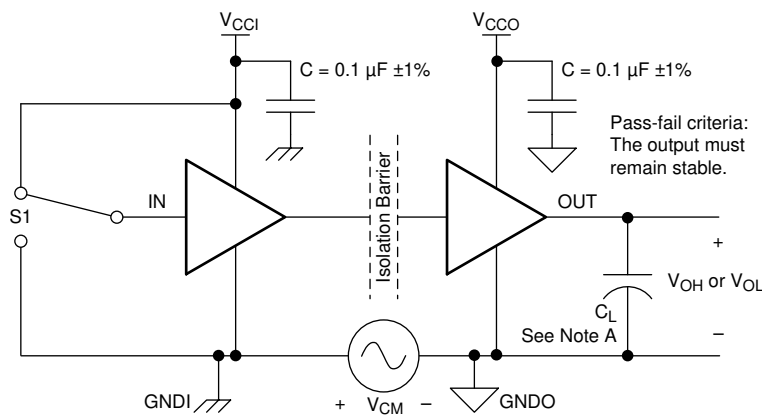

- A. $C_L = 15$ pF and includes instrumentation and fixture capacitance within $\pm 20\%$.

Figure 20. Common-Mode Transient Immunity Test Circuit

8 Detailed Description

8.1 Overview

The ISO776x family of devices uses an ON-OFF keying (OOK) modulation scheme to transmit the digital data across a silicon-dioxide based isolation barrier. The transmitter sends a high-frequency carrier across the barrier to represent one digital state and sends no signal to represent the other digital state. The receiver demodulates the signal after advanced signal conditioning and produces the output through a buffer stage. The ISO776x family of devices also incorporates advanced circuit techniques to maximize the CMTI performance and minimize the radiated emissions because of the high-frequency carrier and IO buffer switching. The conceptual block diagram of a typical channel, [Figure 21](#), shows a functional block diagram of a typical channel. [Figure 22](#) shows a conceptual detail of how the ON-OFF keying scheme works.

8.2 Functional Block Diagram

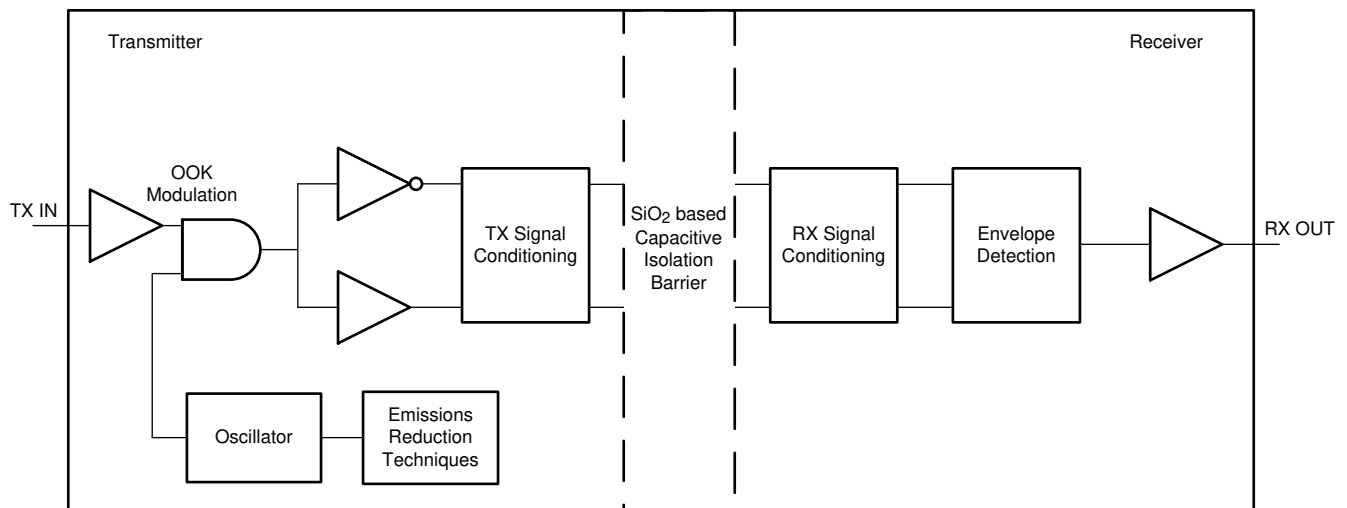

Copyright © 2016, Texas Instruments Incorporated

Figure 21. Conceptual Block Diagram of a Digital Capacitive Isolator

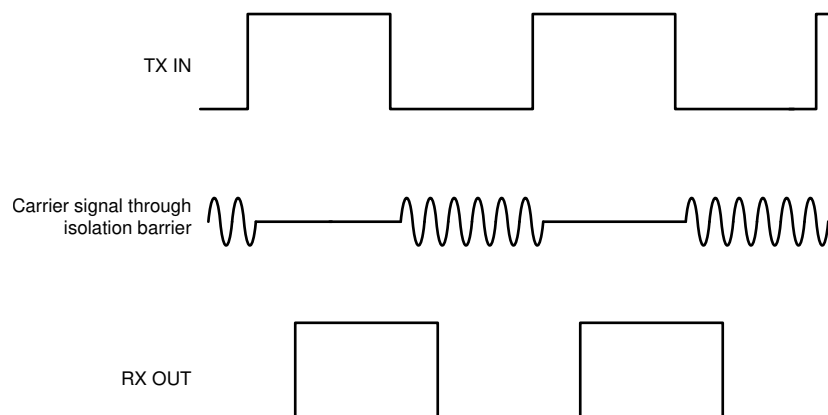

Figure 22. ON-OFF Keying (OOK) Based Modulation Scheme

8.3 Feature Description

Table 1 lists the device features.

Table 1. Device Features

PART NUMBER	CHANNEL DIRECTION	MAXIMUM DATA RATE	DEFAULT OUTPUT	PACKAGE	RATED ISOLATION ⁽¹⁾
ISO7760	6 Forward, 0 Reverse	100 Mbps	High	DW-16	5000 V _{RMS} / 8000 V _{PK}
				DBQ-16	3000 V _{RMS} / 4242 V _{PK}
ISO7760 with F suffix	6 Forward, 0 Reverse	100 Mbps	Low	DW-16	5000 V _{RMS} / 8000 V _{PK}
				DBQ-16	3000 V _{RMS} / 4242 V _{PK}
ISO7761	5 Forward, 1 Reverse	100 Mbps	High	DW-16	5000 V _{RMS} / 7071 V _{PK}
				DBQ-16	3000 V _{RMS} / 4242 V _{PK}
ISO7761 with F suffix	5 Forward, 1 Reverse	100 Mbps	Low	DW-16	5000 V _{RMS} / 7071 V _{PK}
				DBQ-16	3000 V _{RMS} / 4242 V _{PK}
ISO7762	4 Forward, 2 Reverse	100 Mbps	High	DW-16	5000 V _{RMS} / 7071 V _{PK}
				DBQ-16	3000 V _{RMS} / 4242 V _{PK}
ISO7762 with F suffix	4 Forward, 2 Reverse	100 Mbps	Low	DW-16	5000 V _{RMS} / 7071 V _{PK}
				DBQ-16	3000 V _{RMS} / 4242 V _{PK}
ISO7763	3 Forward, 3 Reverse	100 Mbps	High	DW-16	5000 V _{RMS} / 7071 V _{PK}
				DBQ-16	3000 V _{RMS} / 4242 V _{PK}
ISO7763 with F suffix	3 Forward, 3 Reverse	100 Mbps	Low	DW-16	5000 V _{RMS} / 7071 V _{PK}
				DBQ-16	3000 V _{RMS} / 4242 V _{PK}

(1) See [Safety-Related Certifications](#) for detailed isolation ratings.

8.3.1 Electromagnetic Compatibility (EMC) Considerations

Many applications in harsh industrial environment are sensitive to disturbances such as electrostatic discharge (ESD), electrical fast transient (EFT), surge and electromagnetic emissions. These electromagnetic disturbances are regulated by international standards such as IEC 61000-4-x and CISPR 22. Although system-level performance and reliability depends, to a large extent, on the application board design and layout, the ISO776x family of devices incorporates many chip-level design improvements for overall system robustness. Some of these improvements include:

- Robust ESD protection for input and output signal pins and inter-chip bond pads.
- Low-resistance connectivity of ESD cells to supply and ground pins.
- Enhanced performance of high voltage isolation capacitor for better tolerance of ESD, EFT and surge events.
- Bigger on-chip decoupling capacitors to bypass undesirable high energy signals through a low impedance path.
- PMOS and NMOS devices isolated from each other by using guard rings to avoid triggering of parasitic SCRs.
- Reduced common mode currents across the isolation barrier by ensuring purely differential internal operation.

8.4 Device Functional Modes

Table 2 lists the functional modes for the ISO776x.

Table 2. Function Table⁽¹⁾

V _{CCI}	V _{CCO}	INPUT (IN _x) ⁽²⁾	OUTPUT (OUT _x)	COMMENTS
PU	PU	H	H	Normal Operation: A channel output assumes the logic state of the input.
		L	L	
		Open	Default	Default mode: When IN _x is open, the corresponding channel output goes to its default logic state. Default is <i>High</i> for ISO776x and <i>Low</i> for ISO776x with F suffix.
PD	PU	X	Default	Default mode: When V _{CCI} is unpowered, a channel output assumes the logic state based on the selected default option. Default is <i>High</i> for ISO776x and <i>Low</i> for ISO776x with F suffix. When V _{CCI} transitions from unpowered to powered-up, a channel output assumes the logic state of its input. When V _{CCI} transitions from powered-up to unpowered, channel output assumes the selected default state.
X	PD	X	Undetermined	When V _{CCO} is unpowered, a channel output is undetermined ⁽³⁾ . When V _{CCO} transitions from unpowered to powered-up, a channel output assumes the logic state of the input

- (1) V_{CCI} = Input-side V_{CC}; V_{CCO} = Output-side V_{CC}; PU = Powered up (V_{CC} ≥ 2.25 V); PD = Powered down (V_{CC} ≤ 1.7 V); X = Irrelevant; H = High level; L = Low level
- (2) A strongly driven input signal can weakly power the floating V_{CC} via an internal protection diode and cause undetermined output.
- (3) The outputs are in undetermined state when 1.7 V < V_{CCI}, V_{CCO} < 2.25 V.

8.4.1 Device I/O Schematics

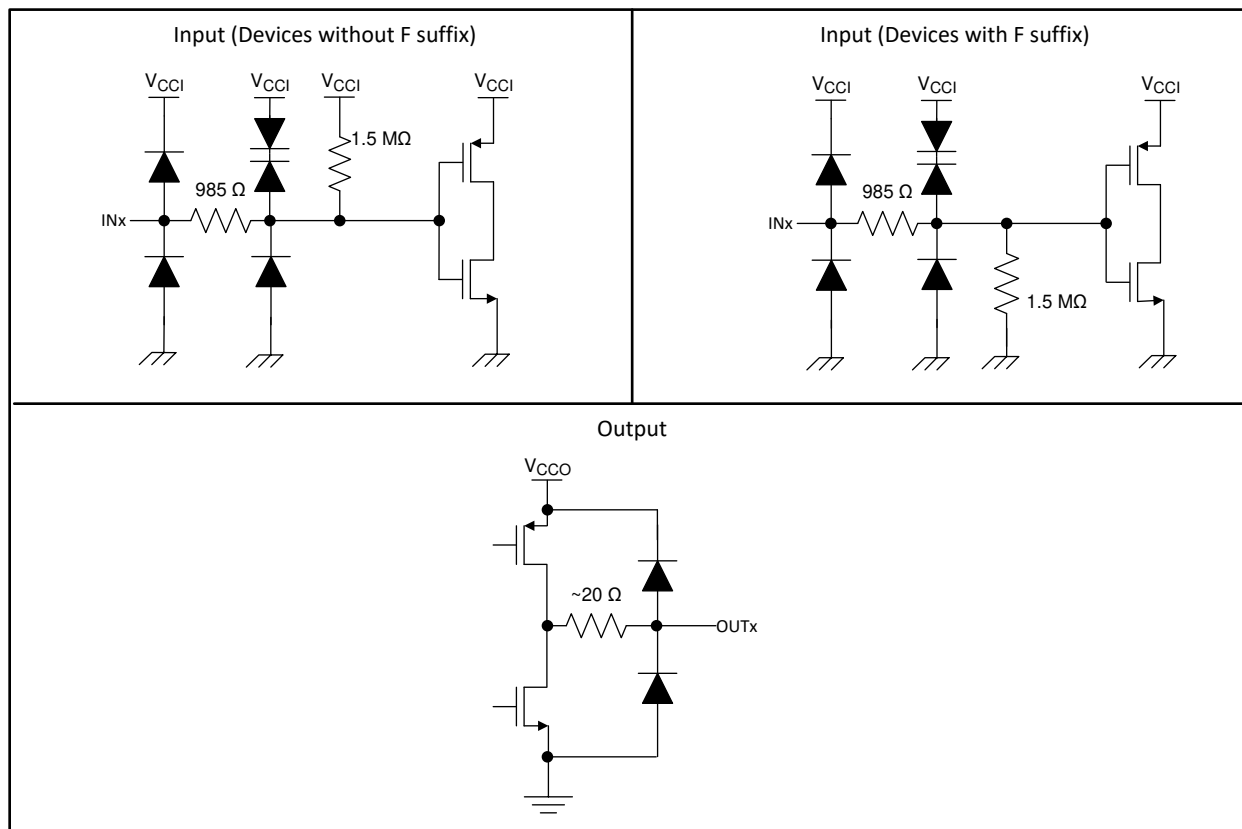

Copyright © 2016, Texas Instruments Incorporated

Figure 23. Device I/O Schematics

9 Application and Implementation

NOTE

Information in the following applications sections is not part of the TI component specification, and TI does not warrant its accuracy or completeness. TI's customers are responsible for determining suitability of components for their purposes. Customers should validate and test their design implementation to confirm system functionality.

9.1 Application Information

The ISO776x family of devices is a high-performance, six-channel digital isolators. The ISO776x family of devices uses single-ended CMOS-logic switching technology. The voltage range is from 2.25 V to 5.5 V for both supplies, V_{CC1} and V_{CC2} . When designing with digital isolators, keep in mind that because of the single-ended design structure, digital isolators do not conform to any specific interface standard and are only intended for isolating single-ended CMOS or TTL digital signal lines. The isolator is typically placed between the data controller (that is, μ C or UART), and a data converter or a line transceiver, regardless of the interface type or standard.

9.2 Typical Application

Figure 24 shows the isolated serial-peripheral interface (SPI) and controller-area network (CAN) interface implementation.

Typical Application (continued)

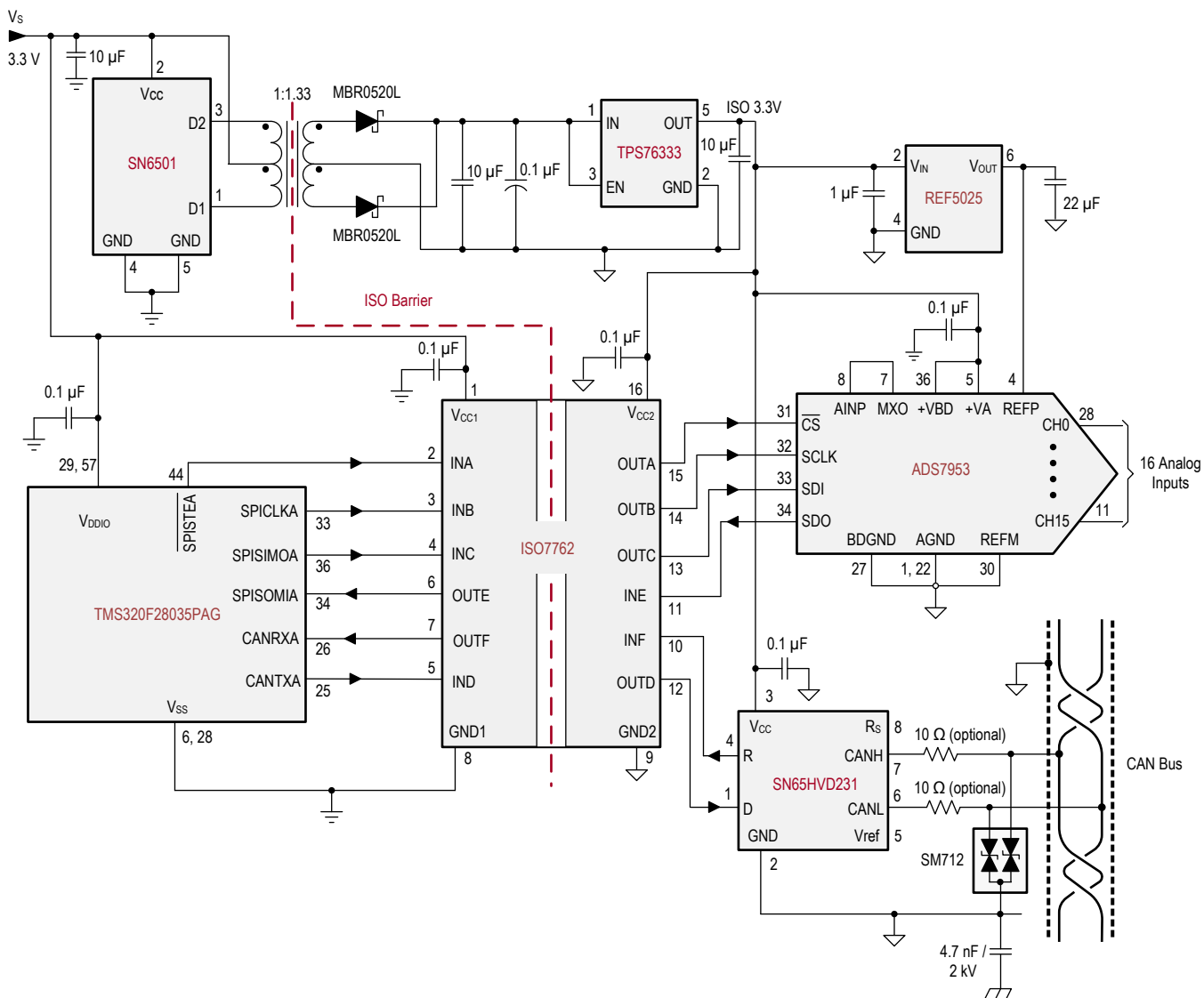

NOTE: Multiple pins and discrete components omitted for clarity purpose.

Figure 24. Isolated SPI and CAN Interface

9.2.1 Design Requirements

For this design example, use the parameters listed in Table 3.

Table 3. Design Parameters

PARAMETER	VALUE
Supply voltage, V_{CC1} and V_{CC2}	2.25 to 5.5 V
Decoupling capacitor between V_{CC1} and GND1	0.1 μ F
Decoupling capacitor from V_{CC2} and GND2	0.1 μ F

9.2.2 Detailed Design Procedure

Unlike optocouplers, which require external components to improve performance, provide bias, or limit current, the ISO776x family of devices only requires two external bypass capacitors to operate.

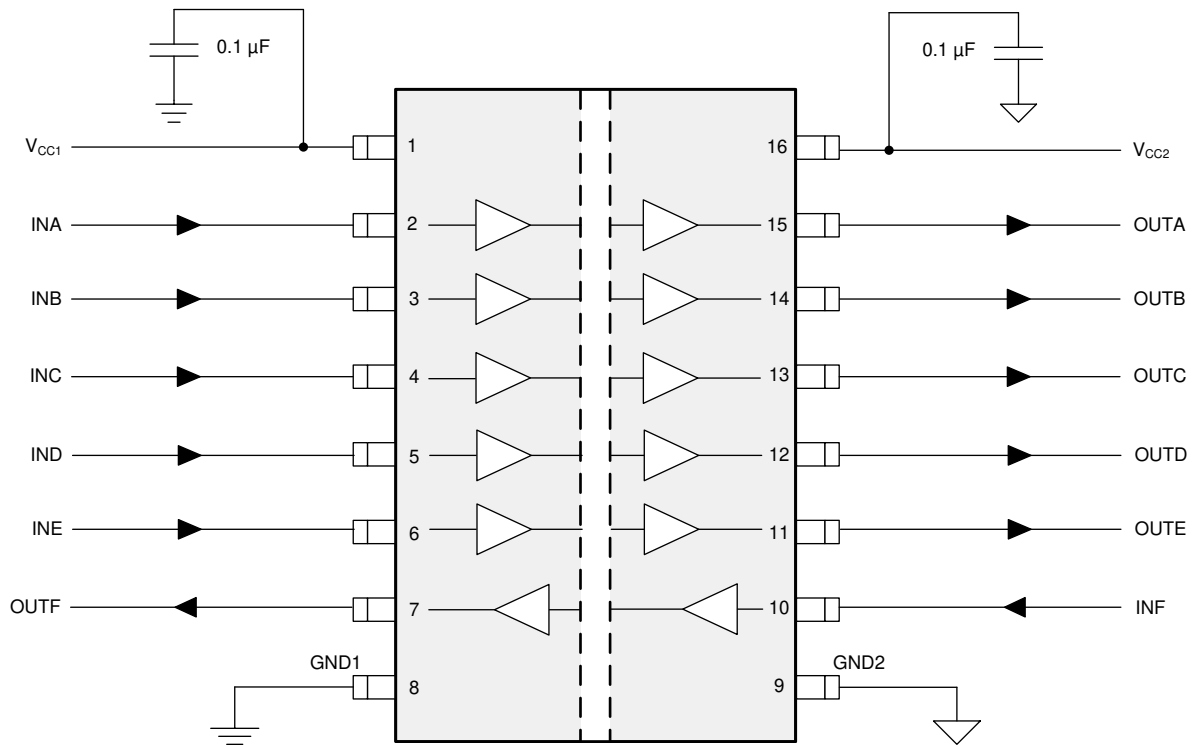

Figure 25. Typical ISO7761 Circuit Hook-up

9.2.3 Application Curves

The typical eye diagram of the ISO776x family of devices indicates low jitter and a wide open eye at the maximum data rate of 100 Mbps.

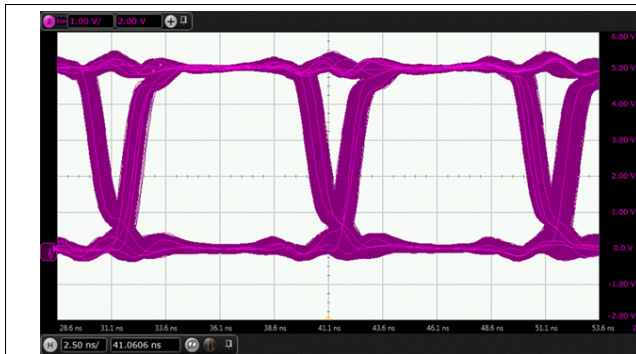

Figure 26. Eye Diagram at 100 Mbps PRBS $2^{16} - 1$ Data, 5 V and 25°C

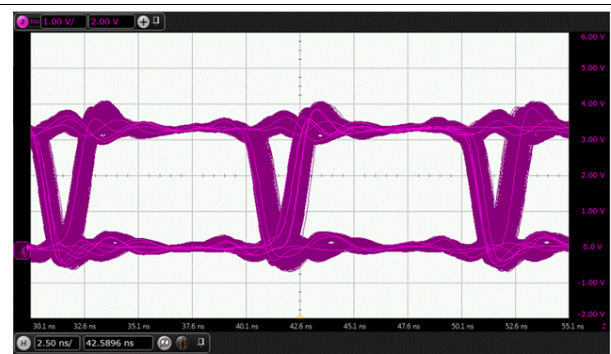

Figure 27. Eye Diagram at 100 Mbps PRBS $2^{16} - 1$ Data, 3.3 V and 25°C

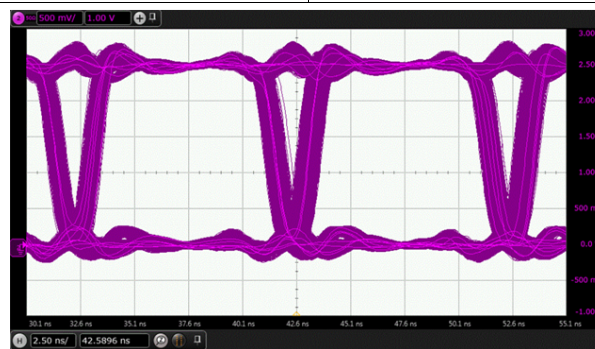

Figure 28. Eye Diagram at 100 Mbps PRBS $2^{16} - 1$ Data, 2.5 V and 25°C

9.2.3.1 Insulation Lifetime

Insulation lifetime projection data is collected by using industry-standard Time Dependent Dielectric Breakdown (TDDB) test method. In this test, all pins on each side of the barrier are tied together creating a two-terminal device and high voltage applied between the two sides; See Figure 29 for TDDB test setup. The insulation breakdown data is collected at various high voltages switching at 60 Hz over temperature. For reinforced insulation, VDE standard requires the use of TDDB projection line with failure rate of less than 1 part per million (ppm). Even though the expected minimum insulation lifetime is 20 years at the specified working isolation voltage, VDE reinforced certification requires additional safety margin of 20% for working voltage and 87.5% for lifetime which translates into minimum required insulation lifetime of 37.5 years at a working voltage that's 20% higher than the specified value.

Figure 30 shows the intrinsic capability of the isolation barrier to withstand high voltage stress over its lifetime. Based on the TDDB data, the intrinsic capability of the insulation is 1500 V_{RMS} with a lifetime of 135 years. Other factors, such as package size, pollution degree, material group, etc. can further limit the working voltage of the component. The working voltage of DW-16 package is specified upto 1500 V_{RMS} and DBQ-16 package up to 400 V_{RMS}. At the lower working voltages, the corresponding insulation lifetime is much longer than 135 years.

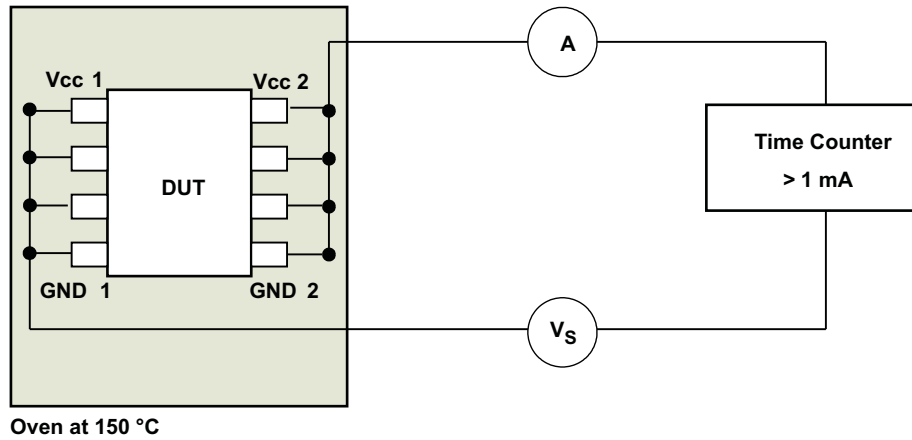

Figure 29. Test Setup for Insulation Lifetime Measurement

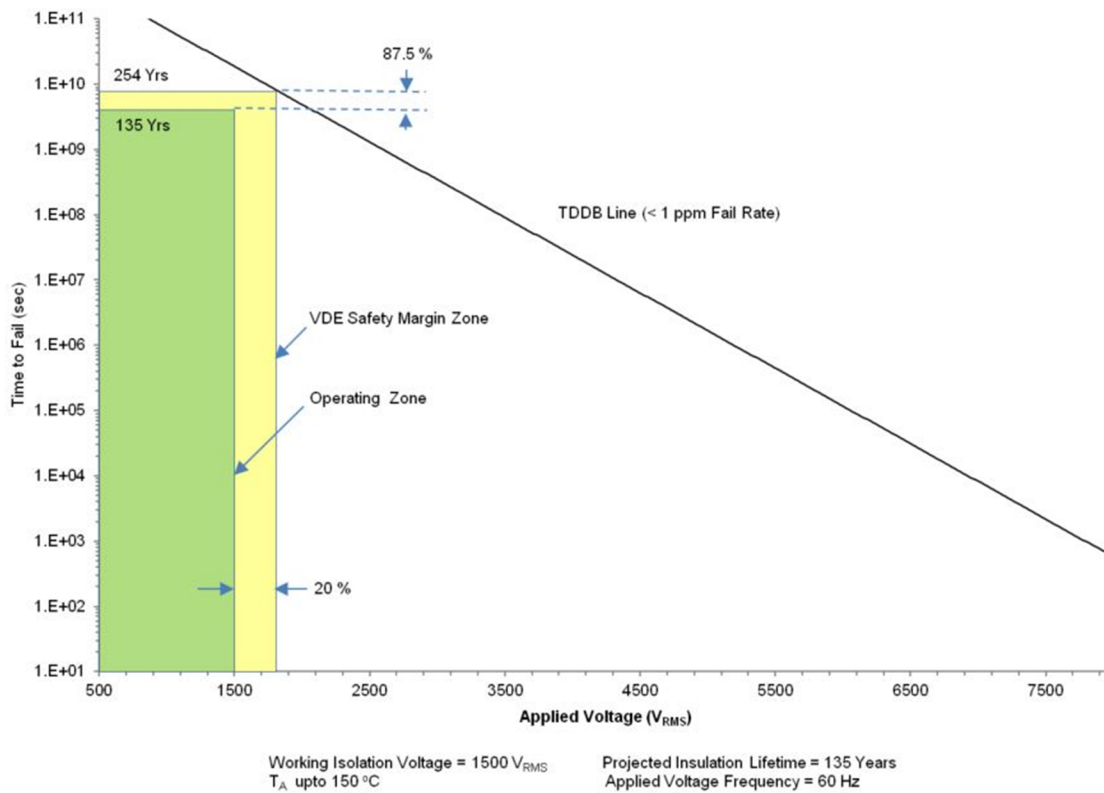

Figure 30. Insulation Lifetime Projection Data

10 Power Supply Recommendations

To help ensure reliable operation at data rates and supply voltages, a 0.1- μ F bypass capacitor is recommended at input and output supply pins (V_{CC1} and V_{CC2}). The capacitors should be placed as close to the supply pins as possible. If only a single primary-side power supply is available in an application, isolated power can be generated for the secondary-side with the help of a transformer driver such as Texas Instruments' [SN6501](#) or [SN6505](#). For such applications, detailed power supply design and transformer selection recommendations are available in the [SN6501 Transformer Driver for Isolated Power Supplies data sheet](#) or the [SN6505 Low-Noise 1-A Transformer Drivers for Isolated Power Supplies data sheet](#).

11 Layout

11.1 Layout Guidelines

A minimum of four layers is required to accomplish a low EMI PCB design (see [Figure 31](#)). Layer stacking should be in the following order (top-to-bottom): high-speed signal layer, ground plane, power plane and low-frequency signal layer.

- Routing the high-speed traces on the top layer avoids the use of vias (and the introduction of their inductances) and allows for clean interconnects between the isolator and the transmitter and receiver circuits of the data link.
- Placing a solid ground plane next to the high-speed signal layer establishes controlled impedance for transmission line interconnects and provides an excellent low-inductance path for the return current flow.
- Placing the power plane next to the ground plane creates additional high-frequency bypass capacitance of approximately 100 pF/inch².
- Routing the slower speed control signals on the bottom layer allows for greater flexibility as these signal links usually have margin to tolerate discontinuities such as vias.

If an additional supply voltage plane or signal layer is needed, add a second power or ground plane system to the stack to keep it symmetrical. This makes the stack mechanically stable and prevents it from warping. Also the power and ground plane of each power system can be placed closer together, thus increasing the high-frequency bypass capacitance significantly.

For detailed layout recommendations, see the [Digital Isolator Design Guide application report](#).

11.1.1 PCB Material

For digital circuit boards operating at less than 150 Mbps, (or rise and fall times greater than 1 ns), and trace lengths of up to 10 inches, use standard FR-4 UL94V-0 printed circuit board. This PCB is preferred over cheaper alternatives because of lower dielectric losses at high frequencies, less moisture absorption, greater strength and stiffness, and the self-extinguishing flammability-characteristics.

11.2 Layout Example

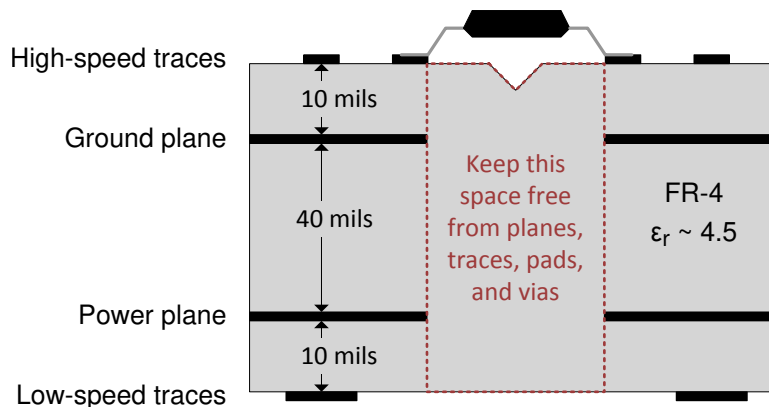

Figure 31. Layout Example Schematic

12 器件和文档支持

12.1 文档支持

12.1.1 相关文档

请参阅如下相关文档：

- 德州仪器 (TI), 《数字隔离器设计指南》应用报告
- 德州仪器 (TI), 《如何通过隔离改善工业系统的 ESD、EFT 和浪涌抗扰性》应用报告
- 德州仪器 (TI), 《隔离相关术语》
- 德州仪器 (TI), 《TMS320F2803x Piccolo™ 微控制器》数据表
- 德州仪器 (TI), 《ADS79xx 12/10/8 位、1 MSPS、16/12/8/4 通道、单端、微功耗串行接口 ADC》数据表
- 德州仪器 (TI), 《REF50xx 低噪声、极低漂移、精密电压基准》数据表
- 德州仪器 (TI), 《SN6501 用于隔离式电源的变压器驱动器》数据表
- 德州仪器 (TI), 《SN65HVD23x 3.3V CAN 总线收发器》数据表
- 德州仪器 (TI), 《TPS76333 低功耗 150mA 低压降线性稳压器》数据表

12.2 相关链接

下表列出了快速访问链接。类别包括技术文档、支持与社区资源、工具和软件，以及申请样片或购买产品的快速链接。

表 4. 相关链接

器件	产品文件夹	样片与购买	技术文档	工具与软件	支持和社区
ISO7760	请单击此处	请单击此处	请单击此处	请单击此处	请单击此处
ISO7761	请单击此处	请单击此处	请单击此处	请单击此处	请单击此处
ISO7762	请单击此处	请单击此处	请单击此处	请单击此处	请单击此处
ISO7763	请单击此处	请单击此处	请单击此处	请单击此处	请单击此处

12.3 接收文档更新通知

要接收文档更新通知，请导航至 TI.com.cn 上的器件产品文件夹。单击右上角的 *通知我* 进行注册，即可每周接收产品信息更改摘要。有关更改的详细信息，请查看任何已修订文档中包含的修订历史记录。

12.4 社区资源

下列链接提供到 TI 社区资源的连接。链接的内容由各个分销商“按照原样”提供。这些内容并不构成 TI 技术规范，并且不一定反映 TI 的观点；请参阅 TI 的《使用条款》。

TI E2E™ Online Community *TI's Engineer-to-Engineer (E2E) Community*. Created to foster collaboration among engineers. At e2e.ti.com, you can ask questions, share knowledge, explore ideas and help solve problems with fellow engineers.

Design Support *TI's Design Support* Quickly find helpful E2E forums along with design support tools and contact information for technical support.

12.5 商标

Piccolo, E2E are trademarks of Texas Instruments.
All other trademarks are the property of their respective owners.

12.6 静电放电警告



ESD 可能会损坏该集成电路。德州仪器 (TI) 建议通过适当的预防措施处理所有集成电路。如果不遵守正确的处理措施和安装程序，可能会损坏集成电路。

ESD 的损坏小至导致微小的性能降级，大至整个器件故障。精密的集成电路可能更容易受到损坏，这是因为非常细微的参数更改都可能会导致器件与其发布的规格不相符。

12.7 术语表

SLYZ022 — *TI* 术语表。

这份术语表列出并解释术语、缩写和定义。

13 机械、封装和可订购信息

以下页面包含机械、封装和可订购信息。这些信息是指定器件的最新可用数据。数据如有变更，恕不另行通知，且不会对此文档进行修订。如需获取此产品说明书的浏览器版本，请查阅左侧的导航栏。



DW0016B

PACKAGE OUTLINE

SOIC - 2.65 mm max height

SOIC

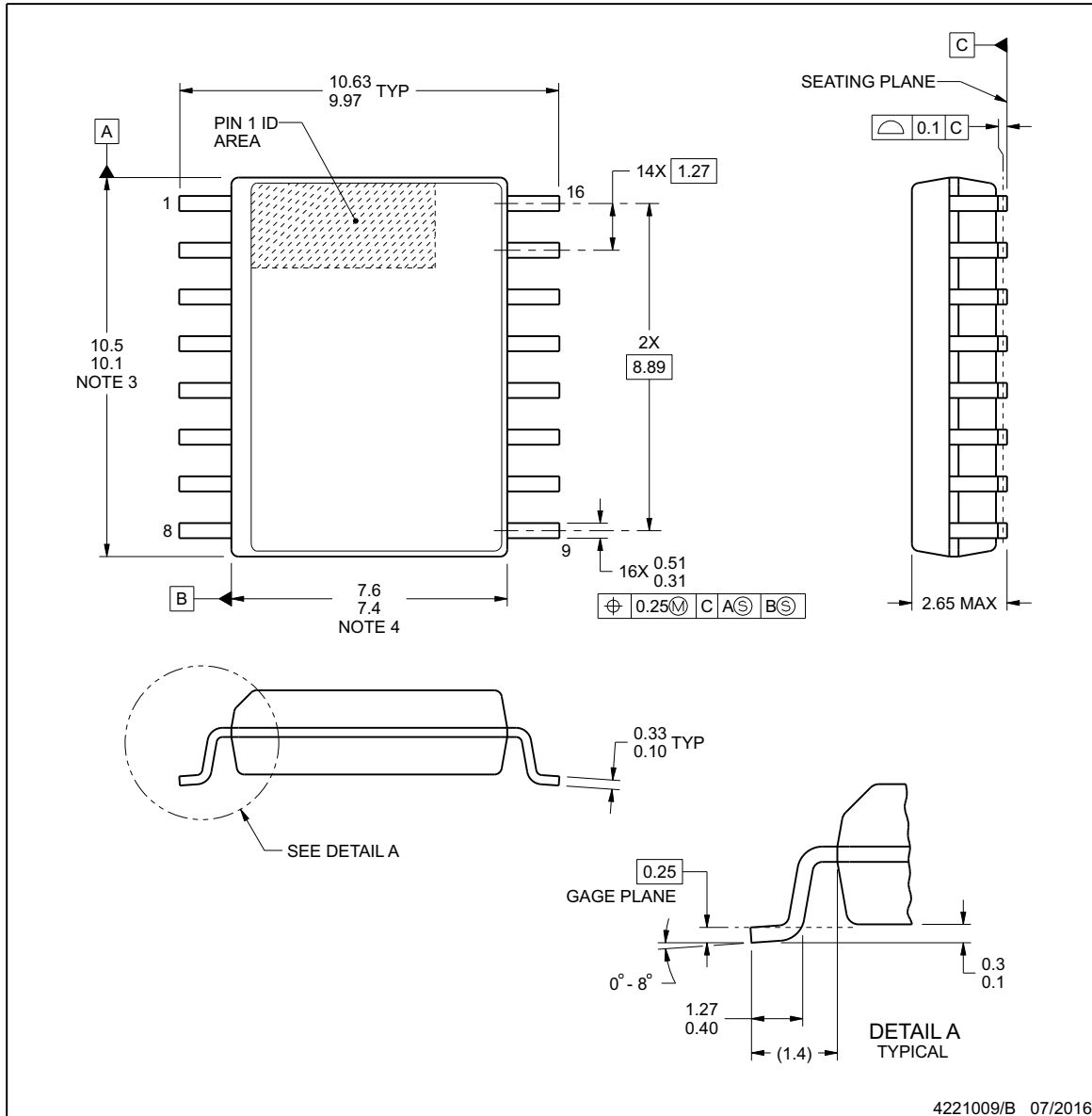

4221009/B 07/2016

NOTES:

1. All linear dimensions are in millimeters. Dimensions in parenthesis are for reference only. Dimensioning and tolerancing per ASME Y14.5M.
2. This drawing is subject to change without notice.
3. This dimension does not include mold flash, protrusions, or gate burrs. Mold flash, protrusions, or gate burrs shall not exceed 0.15 mm, per side.
4. This dimension does not include interlead flash. Interlead flash shall not exceed 0.25 mm, per side.
5. Reference JEDEC registration MS-013.

EXAMPLE BOARD LAYOUT

DW0016B

SOIC - 2.65 mm max height

SOIC

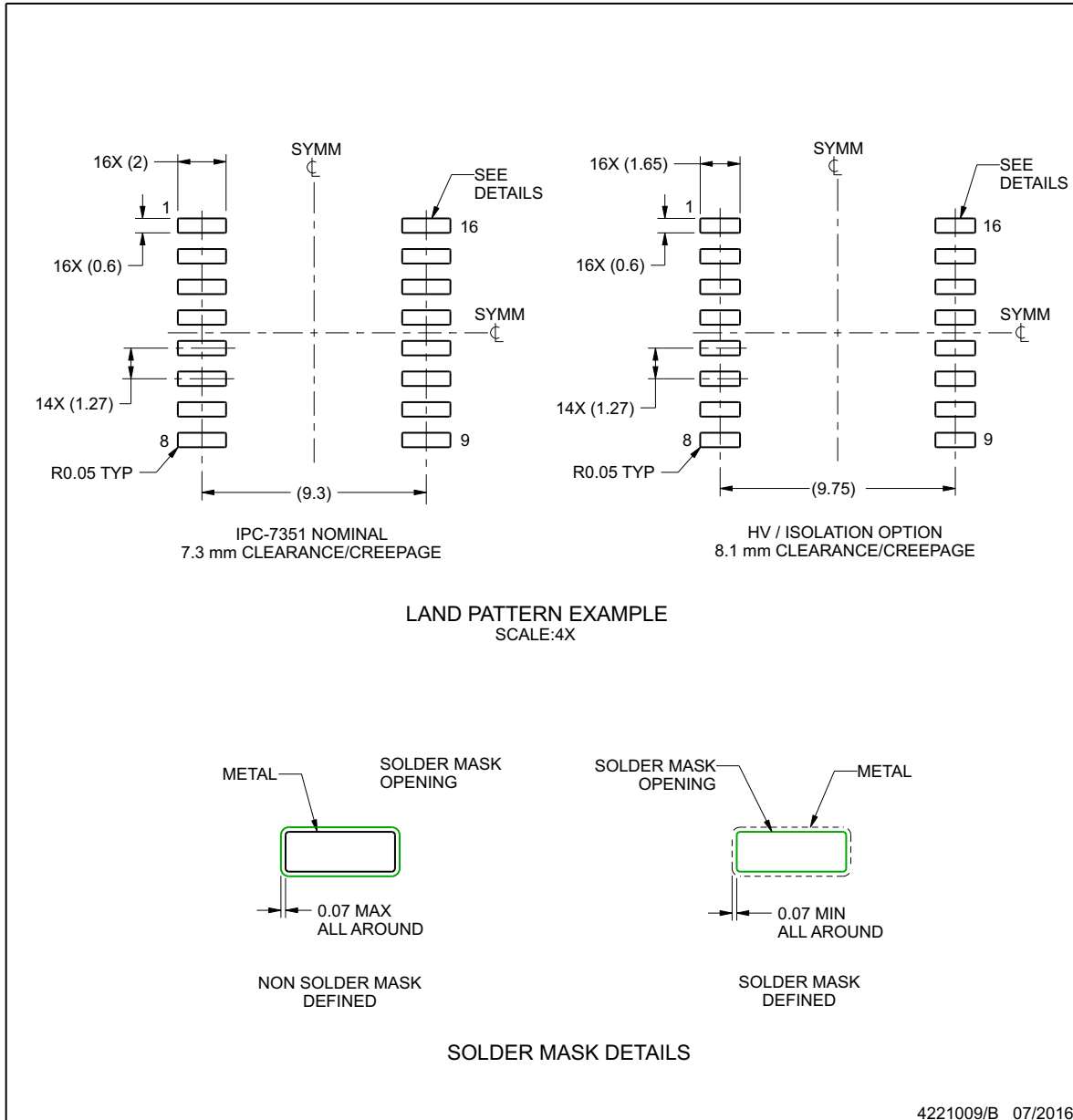

NOTES: (continued)

- 6. Publication IPC-7351 may have alternate designs.
- 7. Solder mask tolerances between and around signal pads can vary based on board fabrication site.

EXAMPLE STENCIL DESIGN

DW0016B

SOIC - 2.65 mm max height

SOIC

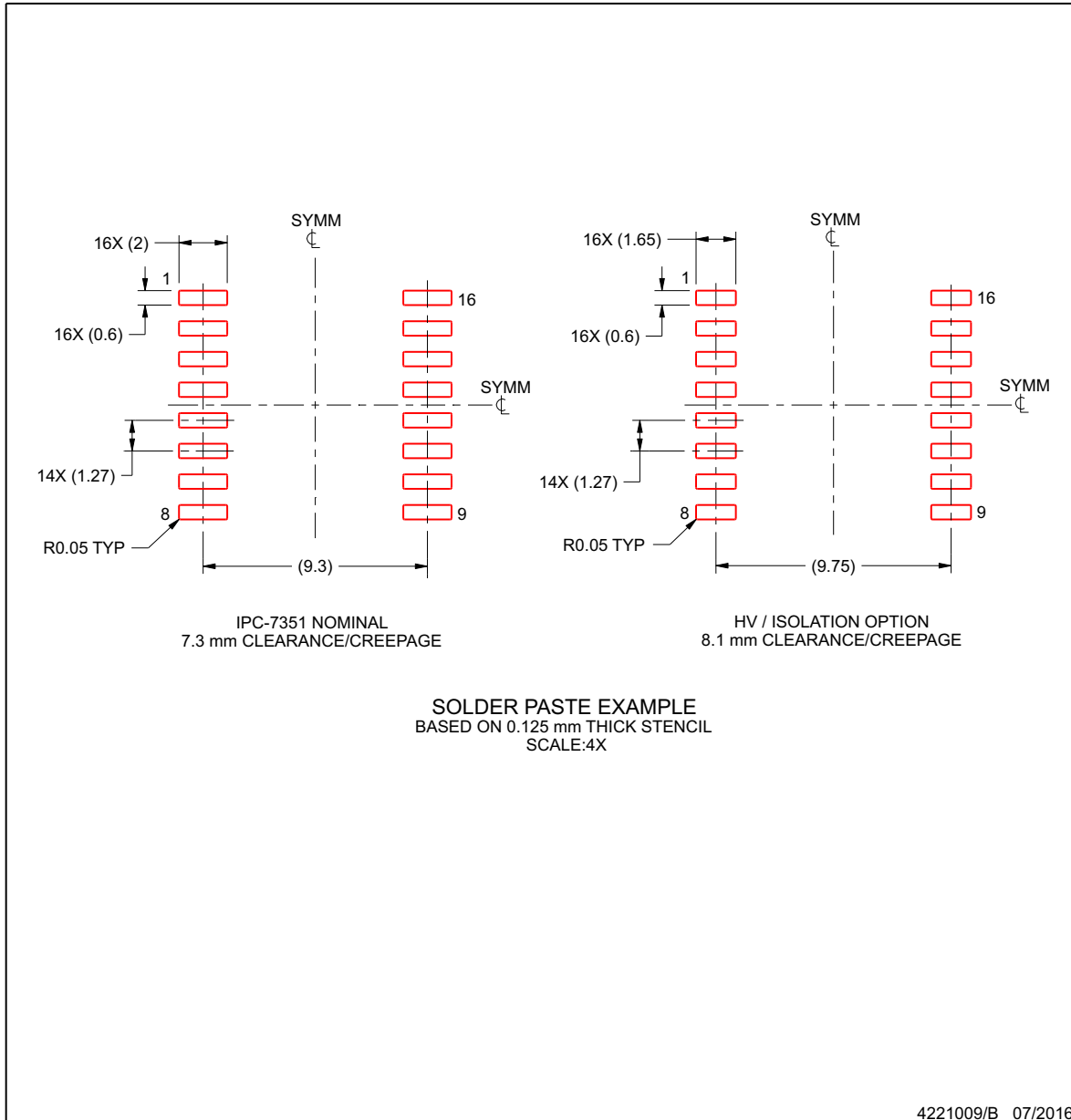

NOTES: (continued)

8. Laser cutting apertures with trapezoidal walls and rounded corners may offer better paste release. IPC-7525 may have alternate design recommendations.
9. Board assembly site may have different recommendations for stencil design.

PACKAGING INFORMATION

Orderable Device	Status (1)	Package Type	Package Drawing	Pins	Package Qty	Eco Plan (2)	Lead finish/ Ball material (6)	MSL Peak Temp (3)	Op Temp (°C)	Device Marking (4/5)	Samples
ISO7760DBQ	ACTIVE	SSOP	DBQ	16	75	RoHS & Green	NIPDAU	Level-2-260C-1 YEAR	-55 to 125	7760	Samples
ISO7760DBQR	ACTIVE	SSOP	DBQ	16	2500	RoHS & Green	NIPDAU	Level-2-260C-1 YEAR	-55 to 125	7760	Samples
ISO7760DW	ACTIVE	SOIC	DW	16	40	RoHS & Green	NIPDAU	Level-2-260C-1 YEAR	-55 to 125	ISO7760	Samples
ISO7760DWR	ACTIVE	SOIC	DW	16	2000	RoHS & Green	NIPDAU	Level-2-260C-1 YEAR	-55 to 125	ISO7760	Samples
ISO7760FDBQ	ACTIVE	SSOP	DBQ	16	75	RoHS & Green	NIPDAU	Level-2-260C-1 YEAR	-55 to 125	7760F	Samples
ISO7760FDBQR	ACTIVE	SSOP	DBQ	16	2500	RoHS & Green	NIPDAU	Level-2-260C-1 YEAR	-55 to 125	7760F	Samples
ISO7760FDW	ACTIVE	SOIC	DW	16	40	RoHS & Green	NIPDAU	Level-2-260C-1 YEAR	-55 to 125	ISO7760F	Samples
ISO7760FDWR	ACTIVE	SOIC	DW	16	2000	RoHS & Green	NIPDAU	Level-2-260C-1 YEAR	-55 to 125	ISO7760F	Samples
ISO7761DBQ	ACTIVE	SSOP	DBQ	16	75	RoHS & Green	NIPDAU	Level-2-260C-1 YEAR	-55 to 125	7761	Samples
ISO7761DBQR	ACTIVE	SSOP	DBQ	16	2500	RoHS & Green	NIPDAU	Level-2-260C-1 YEAR	-55 to 125	7761	Samples
ISO7761DW	ACTIVE	SOIC	DW	16	40	RoHS & Green	NIPDAU	Level-2-260C-1 YEAR	-55 to 125	ISO7761	Samples
ISO7761DWR	ACTIVE	SOIC	DW	16	2000	RoHS & Green	NIPDAU	Level-2-260C-1 YEAR	-55 to 125	ISO7761	Samples
ISO7761FDBQ	ACTIVE	SSOP	DBQ	16	75	RoHS & Green	NIPDAU	Level-2-260C-1 YEAR	-55 to 125	7761F	Samples
ISO7761FDBQR	ACTIVE	SSOP	DBQ	16	2500	RoHS & Green	NIPDAU	Level-2-260C-1 YEAR	-55 to 125	7761F	Samples
ISO7761FDW	ACTIVE	SOIC	DW	16	40	RoHS & Green	NIPDAU	Level-2-260C-1 YEAR	-55 to 125	ISO7761F	Samples
ISO7761FDWR	ACTIVE	SOIC	DW	16	2000	RoHS & Green	NIPDAU	Level-2-260C-1 YEAR	-55 to 125	ISO7761F	Samples
ISO7762DBQ	ACTIVE	SSOP	DBQ	16	75	RoHS & Green	NIPDAU	Level-2-260C-1 YEAR	-55 to 125	7762	Samples
ISO7762DBQR	ACTIVE	SSOP	DBQ	16	2500	RoHS & Green	NIPDAU	Level-2-260C-1 YEAR	-55 to 125	7762	Samples
ISO7762DW	ACTIVE	SOIC	DW	16	40	RoHS & Green	NIPDAU	Level-2-260C-1 YEAR	-55 to 125	ISO7762	Samples
ISO7762DWR	ACTIVE	SOIC	DW	16	2000	RoHS & Green	NIPDAU	Level-2-260C-1 YEAR	-55 to 125	ISO7762	Samples

Orderable Device	Status (1)	Package Type	Package Drawing	Pins	Package Qty	Eco Plan (2)	Lead finish/ Ball material (6)	MSL Peak Temp (3)	Op Temp (°C)	Device Marking (4/5)	Samples
ISO7762FDBQ	ACTIVE	SSOP	DBQ	16	75	RoHS & Green	NIPDAU	Level-2-260C-1 YEAR	-55 to 125	7762F	Samples
ISO7762FDBQR	ACTIVE	SSOP	DBQ	16	2500	RoHS & Green	NIPDAU	Level-2-260C-1 YEAR	-55 to 125	7762F	Samples
ISO7762FDW	ACTIVE	SOIC	DW	16	40	RoHS & Green	NIPDAU	Level-2-260C-1 YEAR	-55 to 125	ISO7762F	Samples
ISO7762FDWR	ACTIVE	SOIC	DW	16	2000	RoHS & Green	NIPDAU	Level-2-260C-1 YEAR	-55 to 125	ISO7762F	Samples
ISO7763DBQ	ACTIVE	SSOP	DBQ	16	75	RoHS & Green	NIPDAU	Level-2-260C-1 YEAR	-55 to 125	7763	Samples
ISO7763DBQR	ACTIVE	SSOP	DBQ	16	2500	RoHS & Green	NIPDAU	Level-2-260C-1 YEAR	-55 to 125	7763	Samples
ISO7763DW	ACTIVE	SOIC	DW	16	40	RoHS & Green	NIPDAU	Level-2-260C-1 YEAR	-55 to 125	ISO7763	Samples
ISO7763DWR	ACTIVE	SOIC	DW	16	2000	RoHS & Green	NIPDAU	Level-2-260C-1 YEAR	-55 to 125	ISO7763	Samples
ISO7763FDBQ	ACTIVE	SSOP	DBQ	16	75	RoHS & Green	NIPDAU	Level-2-260C-1 YEAR	-55 to 125	7763F	Samples
ISO7763FDBQR	ACTIVE	SSOP	DBQ	16	2500	RoHS & Green	NIPDAU	Level-2-260C-1 YEAR	-55 to 125	7763F	Samples
ISO7763FDW	ACTIVE	SOIC	DW	16	40	RoHS & Green	NIPDAU	Level-2-260C-1 YEAR	-55 to 125	ISO7763F	Samples
ISO7763FDWR	ACTIVE	SOIC	DW	16	2000	RoHS & Green	NIPDAU	Level-2-260C-1 YEAR	-55 to 125	ISO7763F	Samples

(1) The marketing status values are defined as follows:

ACTIVE: Product device recommended for new designs.

LIFEBUY: TI has announced that the device will be discontinued, and a lifetime-buy period is in effect.

NRND: Not recommended for new designs. Device is in production to support existing customers, but TI does not recommend using this part in a new design.

PREVIEW: Device has been announced but is not in production. Samples may or may not be available.

OBSOLETE: TI has discontinued the production of the device.

(2) **RoHS:** TI defines "RoHS" to mean semiconductor products that are compliant with the current EU RoHS requirements for all 10 RoHS substances, including the requirement that RoHS substance do not exceed 0.1% by weight in homogeneous materials. Where designed to be soldered at high temperatures, "RoHS" products are suitable for use in specified lead-free processes. TI may reference these types of products as "Pb-Free".

RoHS Exempt: TI defines "RoHS Exempt" to mean products that contain lead but are compliant with EU RoHS pursuant to a specific EU RoHS exemption.

Green: TI defines "Green" to mean the content of Chlorine (Cl) and Bromine (Br) based flame retardants meet JS709B low halogen requirements of <=1000ppm threshold. Antimony trioxide based flame retardants must also meet the <=1000ppm threshold requirement.

(3) MSL, Peak Temp. - The Moisture Sensitivity Level rating according to the JEDEC industry standard classifications, and peak solder temperature.

- (4) There may be additional marking, which relates to the logo, the lot trace code information, or the environmental category on the device.
- (5) Multiple Device Markings will be inside parentheses. Only one Device Marking contained in parentheses and separated by a "~" will appear on a device. If a line is indented then it is a continuation of the previous line and the two combined represent the entire Device Marking for that device.
- (6) Lead finish/Ball material - Orderable Devices may have multiple material finish options. Finish options are separated by a vertical ruled line. Lead finish/Ball material values may wrap to two lines if the finish value exceeds the maximum column width.

Important Information and Disclaimer:The information provided on this page represents TI's knowledge and belief as of the date that it is provided. TI bases its knowledge and belief on information provided by third parties, and makes no representation or warranty as to the accuracy of such information. Efforts are underway to better integrate information from third parties. TI has taken and continues to take reasonable steps to provide representative and accurate information but may not have conducted destructive testing or chemical analysis on incoming materials and chemicals. TI and TI suppliers consider certain information to be proprietary, and thus CAS numbers and other limited information may not be available for release.

In no event shall TI's liability arising out of such information exceed the total purchase price of the TI part(s) at issue in this document sold by TI to Customer on an annual basis.

OTHER QUALIFIED VERSIONS OF ISO7760, ISO7761, ISO7762, ISO7763 :

- Automotive : [ISO7760-Q1](#), [ISO7761-Q1](#), [ISO7762-Q1](#), [ISO7763-Q1](#)

NOTE: Qualified Version Definitions:

- Automotive - Q100 devices qualified for high-reliability automotive applications targeting zero defects

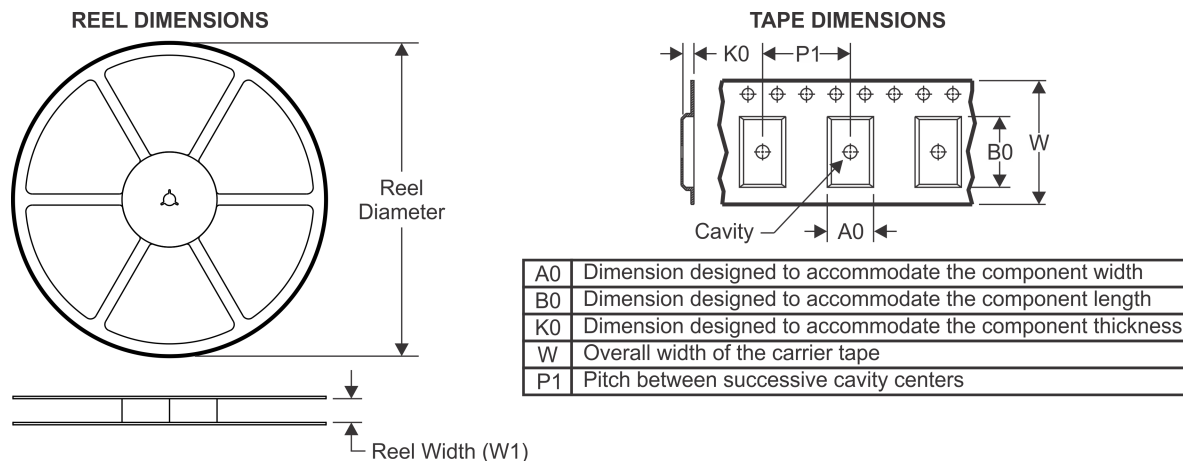
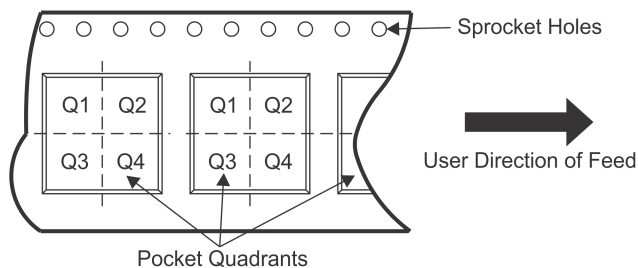
TAPE AND REEL INFORMATION

QUADRANT ASSIGNMENTS FOR PIN 1 ORIENTATION IN TAPE

*All dimensions are nominal

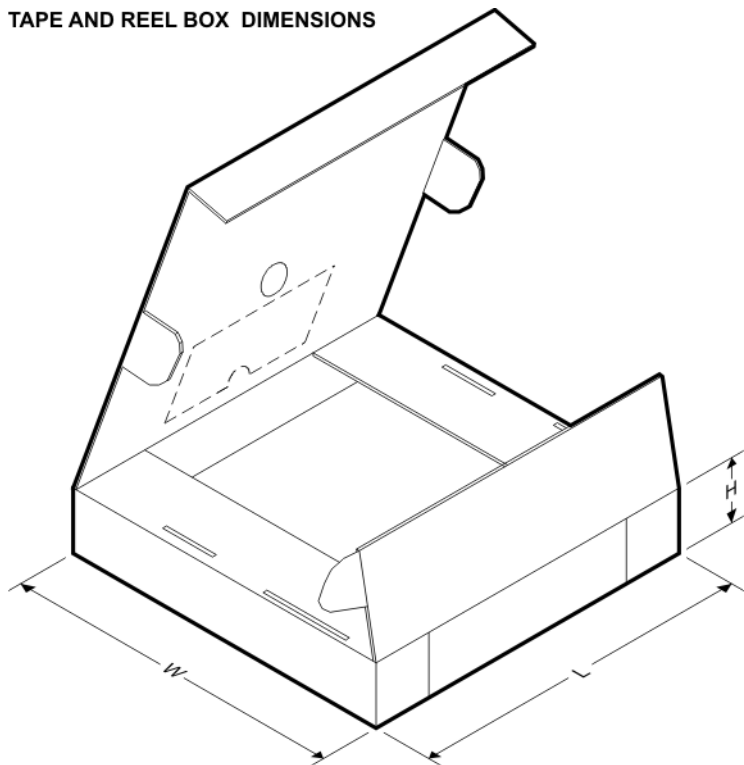
Device	Package Type	Package Drawing	Pins	SPQ	Reel Diameter (mm)	Reel Width W1 (mm)	A0 (mm)	B0 (mm)	K0 (mm)	P1 (mm)	W (mm)	Pin1 Quadrant
ISO7760DBQR	SSOP	DBQ	16	2500	330.0	12.4	6.4	5.2	2.1	8.0	12.0	Q1
ISO7760DWR	SOIC	DW	16	2000	330.0	16.4	10.75	10.7	2.7	12.0	16.0	Q1
ISO7760FDBQR	SSOP	DBQ	16	2500	330.0	12.4	6.4	5.2	2.1	8.0	12.0	Q1
ISO7760FDWR	SOIC	DW	16	2000	330.0	16.4	10.75	10.7	2.7	12.0	16.0	Q1
ISO7761DBQR	SSOP	DBQ	16	2500	330.0	12.4	6.4	5.2	2.1	8.0	12.0	Q1
ISO7761DWR	SOIC	DW	16	2000	330.0	16.4	10.75	10.7	2.7	12.0	16.0	Q1
ISO7761FDBQR	SSOP	DBQ	16	2500	330.0	12.4	6.4	5.2	2.1	8.0	12.0	Q1
ISO7761FDWR	SOIC	DW	16	2000	330.0	16.4	10.75	10.7	2.7	12.0	16.0	Q1
ISO7762DBQR	SSOP	DBQ	16	2500	330.0	12.4	6.4	5.2	2.1	8.0	12.0	Q1
ISO7762DWR	SOIC	DW	16	2000	330.0	16.4	10.75	10.7	2.7	12.0	16.0	Q1
ISO7762FDBQR	SSOP	DBQ	16	2500	330.0	12.4	6.4	5.2	2.1	8.0	12.0	Q1
ISO7762FDWR	SOIC	DW	16	2000	330.0	16.4	10.75	10.7	2.7	12.0	16.0	Q1
ISO7763DBQR	SSOP	DBQ	16	2500	330.0	12.4	6.4	5.2	2.1	8.0	12.0	Q1
ISO7763DWR	SOIC	DW	16	2000	330.0	16.4	10.75	10.7	2.7	12.0	16.0	Q1
ISO7763FDBQR	SSOP	DBQ	16	2500	330.0	12.4	6.4	5.2	2.1	8.0	12.0	Q1
ISO7763FDWR	SOIC	DW	16	2000	330.0	16.4	10.75	10.7	2.7	12.0	16.0	Q1

TAPE AND REEL BOX DIMENSIONS

*All dimensions are nominal

Device	Package Type	Package Drawing	Pins	SPQ	Length (mm)	Width (mm)	Height (mm)
ISO7760DBQR	SSOP	DBQ	16	2500	350.0	350.0	43.0
ISO7760DWR	SOIC	DW	16	2000	350.0	350.0	43.0
ISO7760FDBQR	SSOP	DBQ	16	2500	350.0	350.0	43.0
ISO7760FDWR	SOIC	DW	16	2000	350.0	350.0	43.0
ISO7761DBQR	SSOP	DBQ	16	2500	350.0	350.0	43.0
ISO7761DWR	SOIC	DW	16	2000	350.0	350.0	43.0
ISO7761FDBQR	SSOP	DBQ	16	2500	350.0	350.0	43.0
ISO7761FDWR	SOIC	DW	16	2000	350.0	350.0	43.0
ISO7762DBQR	SSOP	DBQ	16	2500	350.0	350.0	43.0
ISO7762DWR	SOIC	DW	16	2000	350.0	350.0	43.0
ISO7762FDBQR	SSOP	DBQ	16	2500	350.0	350.0	43.0
ISO7762FDWR	SOIC	DW	16	2000	350.0	350.0	43.0
ISO7763DBQR	SSOP	DBQ	16	2500	350.0	350.0	43.0
ISO7763DWR	SOIC	DW	16	2000	350.0	350.0	43.0
ISO7763FDBQR	SSOP	DBQ	16	2500	350.0	350.0	43.0
ISO7763FDWR	SOIC	DW	16	2000	535.4	167.6	48.3

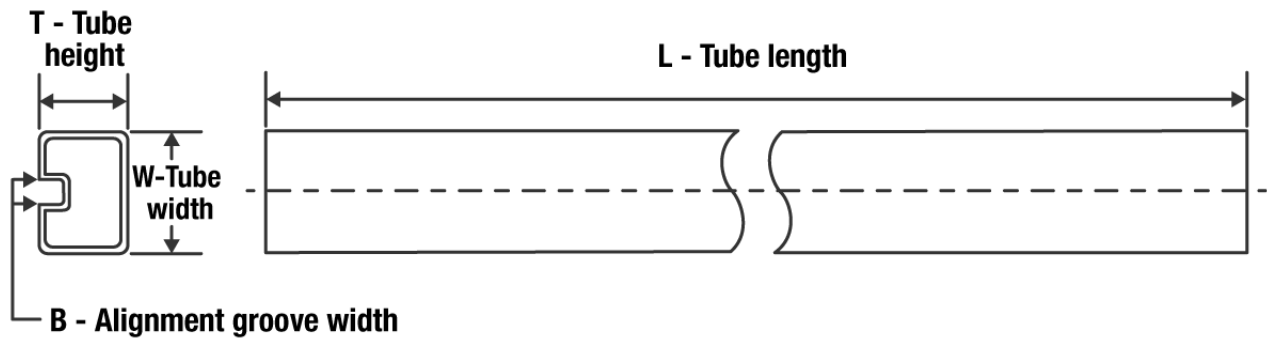
TUBE

*All dimensions are nominal

Device	Package Name	Package Type	Pins	SPQ	L (mm)	W (mm)	T (μm)	B (mm)
ISO7760DBQ	DBQ	SSOP	16	75	505.46	6.76	3810	4
ISO7760DW	DW	SOIC	16	40	506.98	12.7	4826	6.6
ISO7760FDBQ	DBQ	SSOP	16	75	505.46	6.76	3810	4
ISO7760FDW	DW	SOIC	16	40	506.98	12.7	4826	6.6
ISO7761DBQ	DBQ	SSOP	16	75	505.46	6.76	3810	4
ISO7761DW	DW	SOIC	16	40	506.98	12.7	4826	6.6
ISO7761FDBQ	DBQ	SSOP	16	75	505.46	6.76	3810	4
ISO7761FDW	DW	SOIC	16	40	506.98	12.7	4826	6.6
ISO7762DBQ	DBQ	SSOP	16	75	505.46	6.76	3810	4
ISO7762DW	DW	SOIC	16	40	506.98	12.7	4826	6.6
ISO7762FDBQ	DBQ	SSOP	16	75	505.46	6.76	3810	4
ISO7762FDW	DW	SOIC	16	40	506.98	12.7	4826	6.6
ISO7763DBQ	DBQ	SSOP	16	75	505.46	6.76	3810	4
ISO7763DW	DW	SOIC	16	40	506.98	12.7	4826	6.6
ISO7763FDBQ	DBQ	SSOP	16	75	505.46	6.76	3810	4
ISO7763FDW	DW	SOIC	16	40	506.98	12.7	4826	6.6

GENERIC PACKAGE VIEW

DW 16

SOIC - 2.65 mm max height

7.5 x 10.3, 1.27 mm pitch

SMALL OUTLINE INTEGRATED CIRCUIT

This image is a representation of the package family, actual package may vary.
Refer to the product data sheet for package details.

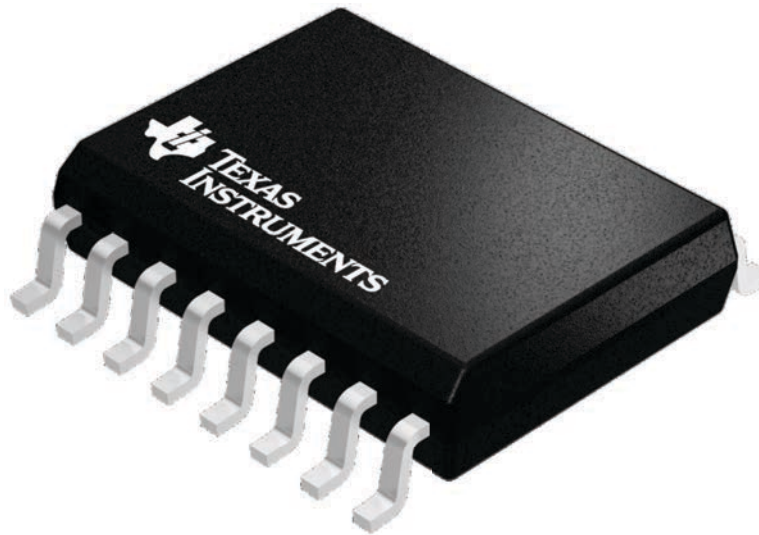

4224780/A

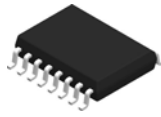

DW0016B

PACKAGE OUTLINE

SOIC - 2.65 mm max height

SOIC

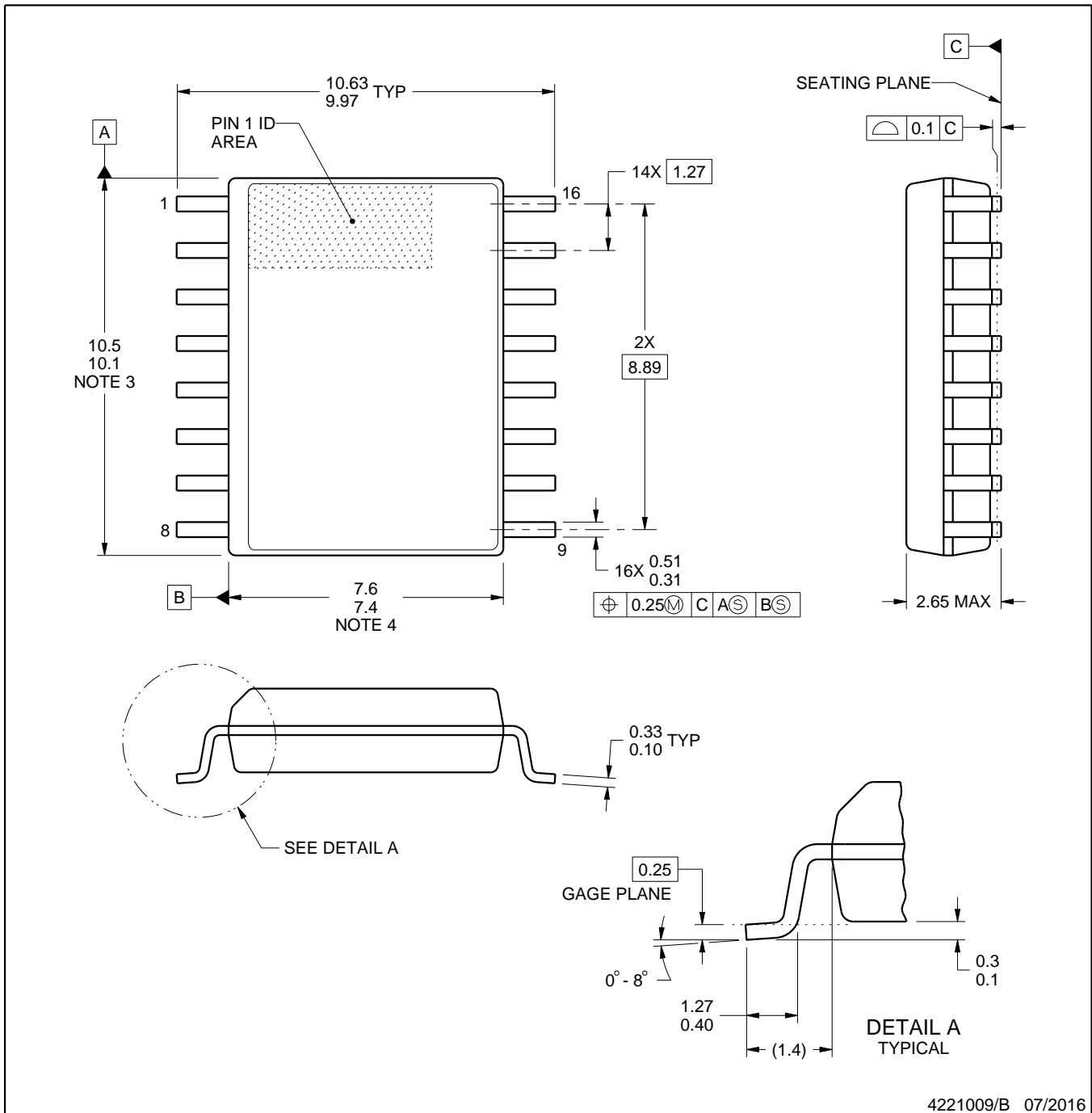

4221009/B 07/2016

NOTES:

1. All linear dimensions are in millimeters. Dimensions in parenthesis are for reference only. Dimensioning and tolerancing per ASME Y14.5M.
2. This drawing is subject to change without notice.
3. This dimension does not include mold flash, protrusions, or gate burrs. Mold flash, protrusions, or gate burrs shall not exceed 0.15 mm, per side.
4. This dimension does not include interlead flash. Interlead flash shall not exceed 0.25 mm, per side.
5. Reference JEDEC registration MS-013.

EXAMPLE BOARD LAYOUT

DW0016B

SOIC - 2.65 mm max height

SOIC

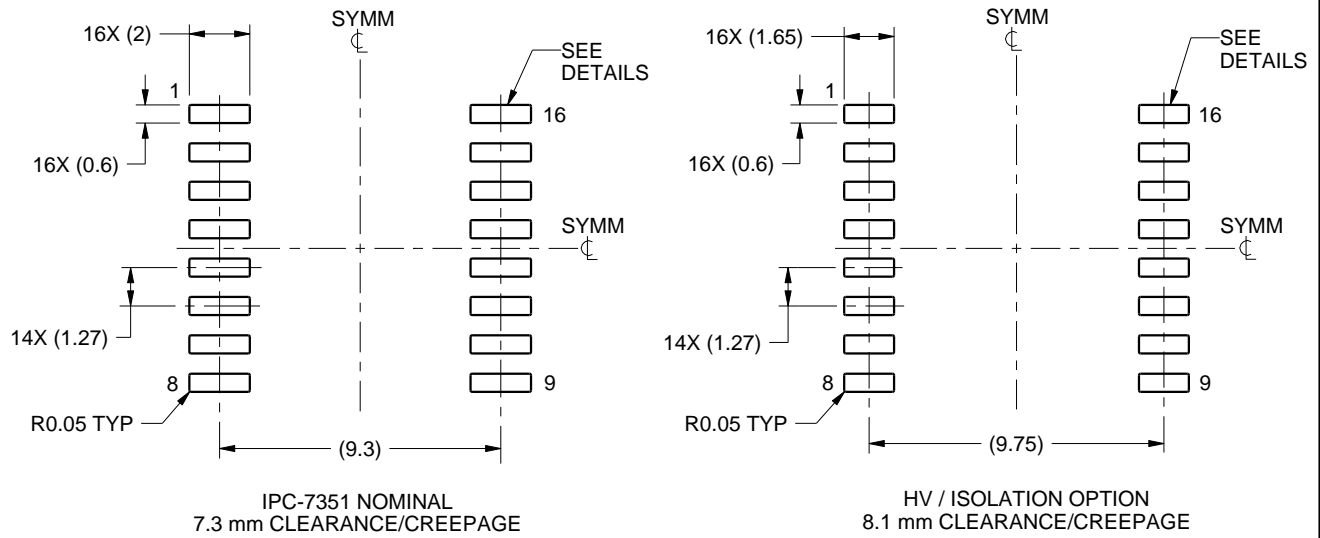

LAND PATTERN EXAMPLE
SCALE:4X

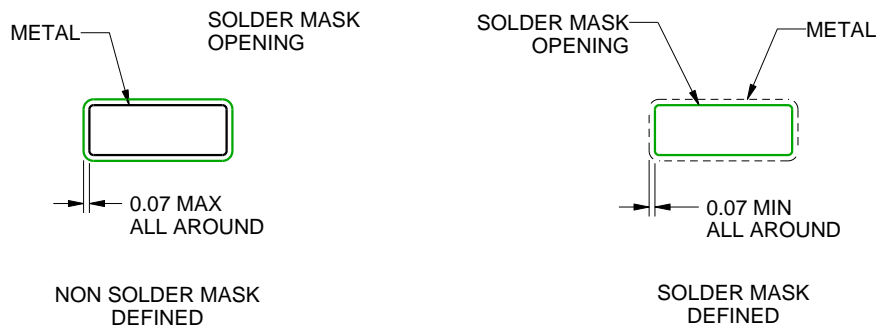

SOLDER MASK DETAILS

4221009/B 07/2016

NOTES: (continued)

- 6. Publication IPC-7351 may have alternate designs.
- 7. Solder mask tolerances between and around signal pads can vary based on board fabrication site.

EXAMPLE STENCIL DESIGN

DW0016B

SOIC - 2.65 mm max height

SOIC

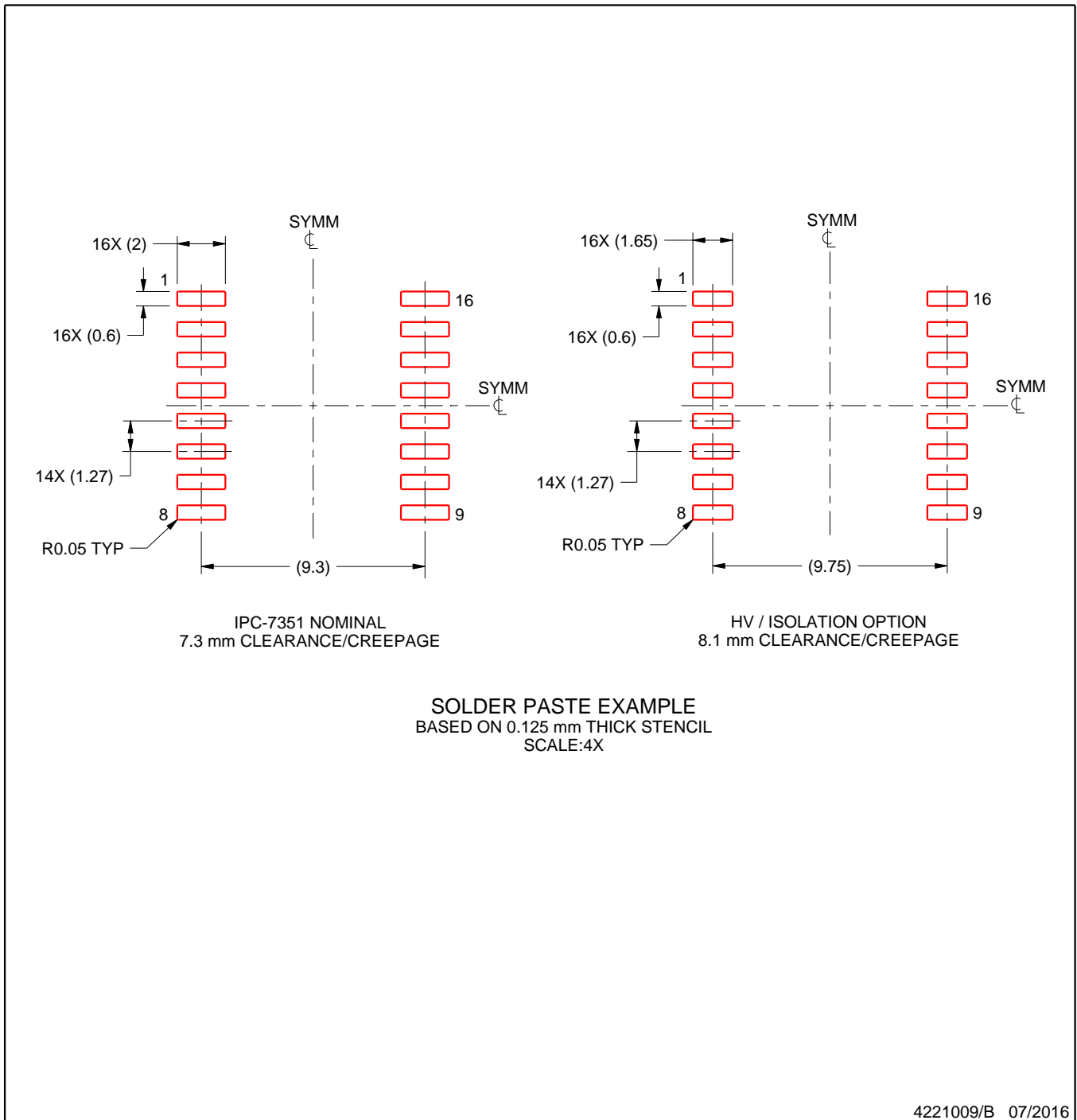

NOTES: (continued)

8. Laser cutting apertures with trapezoidal walls and rounded corners may offer better paste release. IPC-7525 may have alternate design recommendations.
9. Board assembly site may have different recommendations for stencil design.

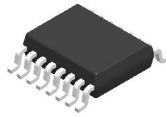

DBQ0016A

PACKAGE OUTLINE

SSOP - 1.75 mm max height

SHRINK SMALL-OUTLINE PACKAGE

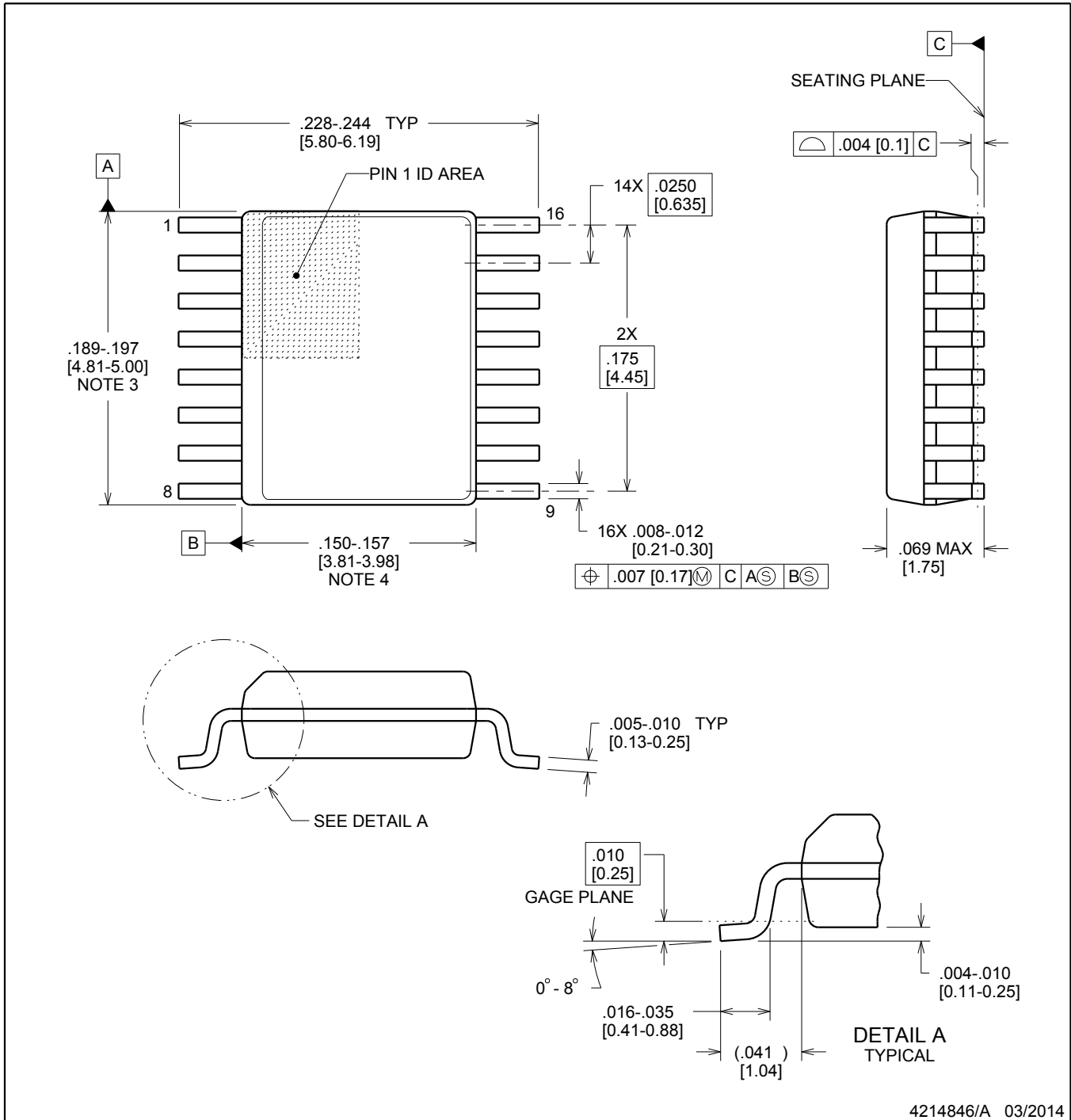

4214846/A 03/2014

NOTES:

- Linear dimensions are in inches [millimeters]. Dimensions in parenthesis are for reference only. Controlling dimensions are in inches. Dimensioning and tolerancing per ASME Y14.5M.
- This drawing is subject to change without notice.
- This dimension does not include mold flash, protrusions, or gate burrs. Mold flash, protrusions, or gate burrs shall not exceed .006 inch, per side.
- This dimension does not include interlead flash.
- Reference JEDEC registration MO-137, variation AB.

EXAMPLE BOARD LAYOUT

DBQ0016A

SSOP - 1.75 mm max height

SHRINK SMALL-OUTLINE PACKAGE

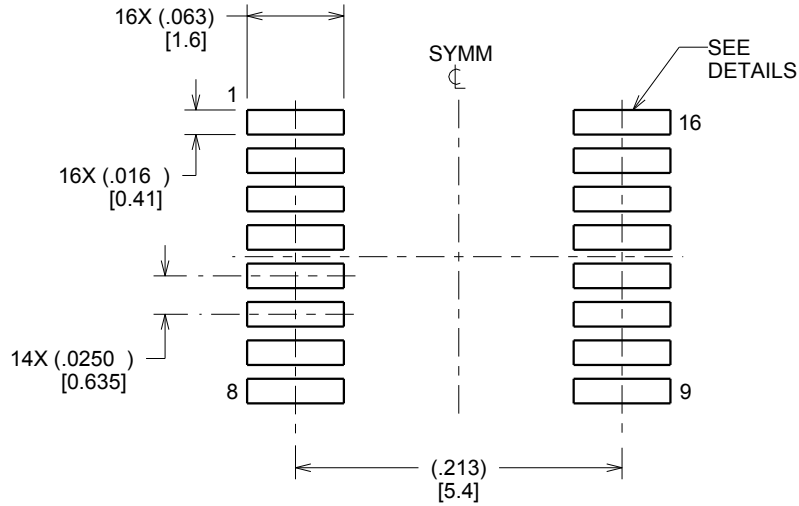

LAND PATTERN EXAMPLE
SCALE:8X

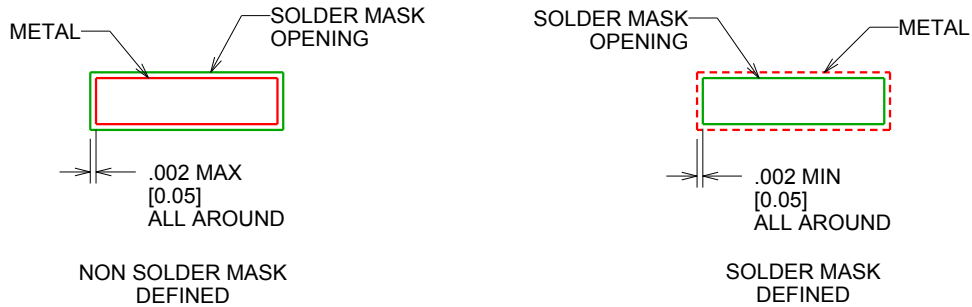

SOLDER MASK DETAILS

4214846/A 03/2014

NOTES: (continued)

- 6. Publication IPC-7351 may have alternate designs.
- 7. Solder mask tolerances between and around signal pads can vary based on board fabrication site.

EXAMPLE STENCIL DESIGN

DBQ0016A

SSOP - 1.75 mm max height

SHRINK SMALL-OUTLINE PACKAGE

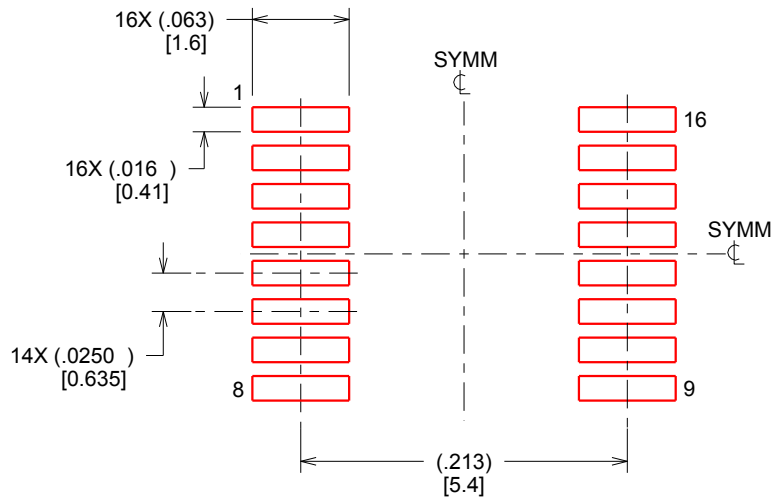

SOLDER PASTE EXAMPLE
BASED ON .005 INCH [0.127 MM] THICK STENCIL
SCALE:8X

4214846/A 03/2014

NOTES: (continued)

8. Laser cutting apertures with trapezoidal walls and rounded corners may offer better paste release. IPC-7525 may have alternate design recommendations.
9. Board assembly site may have different recommendations for stencil design.

重要声明和免责声明

TI“按原样”提供技术和可靠性数据（包括数据表）、设计资源（包括参考设计）、应用或其他设计建议、网络工具、安全信息和其他资源，不保证没有瑕疵且不做任何明示或暗示的担保，包括但不限于对适销性、某特定用途方面的适用性或不侵犯任何第三方知识产权的暗示担保。

这些资源可供使用 TI 产品进行设计的熟练开发人员使用。您将自行承担以下全部责任：(1) 针对您的应用选择合适的 TI 产品，(2) 设计、验证并测试您的应用，(3) 确保您的应用满足相应标准以及任何其他功能安全、信息安全、监管或其他要求。

这些资源如有变更，恕不另行通知。TI 授权您仅可将这些资源用于研发本资源所述的 TI 产品的应用。严禁对这些资源进行其他复制或展示。您无权使用任何其他 TI 知识产权或任何第三方知识产权。您应全额赔偿因在这些资源的使用中对 TI 及其代表造成的任何索赔、损害、成本、损失和债务，TI 对此概不负责。

TI 提供的产品受 [TI 的销售条款](#) 或 [ti.com](#) 上其他适用条款/TI 产品随附的其他适用条款的约束。TI 提供这些资源并不会扩展或以其他方式更改 TI 针对 TI 产品发布的适用的担保或担保免责声明。

TI 反对并拒绝您可能提出的任何其他或不同的条款。

邮寄地址：Texas Instruments, Post Office Box 655303, Dallas, Texas 75265

Copyright © 2022，德州仪器 (TI) 公司