

LMUN5211DW1T1G

S-LMUN5211DW1T1G

Dual Bias Resistor Transistors
NPN Silicon Surface Mount Transistors
with Monolithic Bias Resistor Network

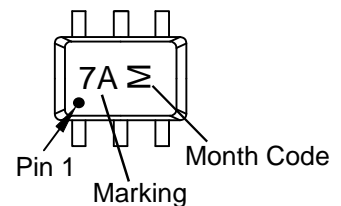
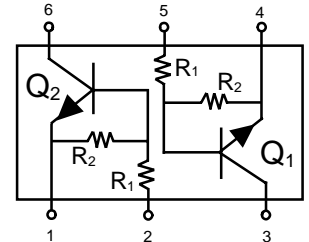
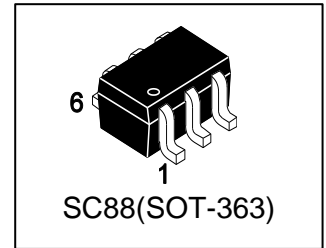

1. FEATURES

- Simplifies circuit design
- Reduces board space.
- Reduces Component Count
- We declare that the material of product compliance with RoHS requirements and Halogen Free.
- S- prefix for automotive and other applications requiring unique site and control change requirements; AEC-Q101 qualified and PPAP capable.

2. DEVICE MARKING AND RESISTOR VALUES

Device	Marking	R1(K)	R2(K)	Vin(V)	Shipping
LMUN5211DW1T1G	7A	10	10	-10~+40	3000/Tape&Reel
LMUN5211DW1T3G	7A	10	10	-10~+40	10000/Tape&Reel

3. MAXIMUM RATINGS(Ta = 25°C)

Parameter	Symbol	Limits	Unit
Collector–Emitter Voltage	VCEO	50	V
Collector–Base Voltage	VCBO	50	V
Emitter–Base Breakdown Voltage	VEBO	6	V
Collector Current — Continuous	IC	100	mA

4. THERMAL CHARACTERISTICS

Parameter (One Junction Heated)	Symbol	Limits	Unit
Total Device Dissipation, (Note 1) @ TA = 25°C Derate above 25°C	PD	187 1.5	mW mW/°C
Thermal Resistance, Junction–to–Ambient(Note 1)	ROJA	670	°C/W
Parameter (Both Junctions Heated)	Symbol	Limits	Unit
Total Device Dissipation, (Note 1) @ TA = 25°C Derate above 25°C	PD	250 2	mW mW/°C
Thermal Resistance, Junction–to–Ambient(Note 1)	ROJA	493	°C/W
Thermal Resistance, Junction–to–Lead(Note 1)	ROJL	188	°C/W
Junction and Storage temperature	TJ, Tstg	-55~+150	°C

1. FR-4 @ Minimum Pad

5. ELECTRICAL CHARACTERISTICS (Ta= 25°C)

OFF CHARACTERISTICS

Characteristic	Symbol	Min.	Typ.	Max.	Unit
Collector–Emitter Breakdown Voltage (IC = 2.0 mA, IB = 0)	VBR(CEO)	50	-	-	V
Collector–Base Breakdown Voltage (IC = 10 μA, IE = 0)	VBR(CBO)	50	-	-	V
Emitter–Base Breakdown Voltage (IE = 200 μA, IC = 0)	VBR(EBO)	6	-	-	V
Collector-Base Cutoff Current (VCB = 50 V, IE = 0)	ICBO	-	-	100	nA
Collector-Emitter Cutoff Current (VCE = 50 V, IB = 0)	ICEO	-	-	500	nA
Emitter-Base Cutoff Current (VEB = 6.0 V, IC = 0)	IEBO	-	-	0.5	mA

ON CHARACTERISTICS (Note 2.)

DC Current Gain (IC = 5.0 mA, VCE = 10 V)	HFE	35	-	-	
Collector–Emitter Saturation Voltage (IC = 10 mA, IB = 0.3 mA)	VCE(sat)	-	-	0.25	V
On-State Input Voltage (VCE=0.2V, IC=5mA)	VI(on)	-	1.5	-	V
Off-State Input Voltage (VCE=5V, IC=0.1mA)	VI(off)	-	1	-	V
Output Voltage (on) (VCC = 5.0 V, VB = 2.5 V, RL = 1.0KΩ)	VOL	-	-	0.2	V
Output Voltage (off) (VCC = 5.0 V, VB = 0.5 V, RL = 1.0KΩ)	VOH	4.9	-	-	V
Input Resistor	R1	7	10	13	KΩ
Resistor Ratio	R1/R2	0.8	1	1.2	

2. Pulse Test: Pulse Width < 300 μs, Duty Cycle < 2.0%

6.ELECTRICAL CHARACTERISTICS CURVES

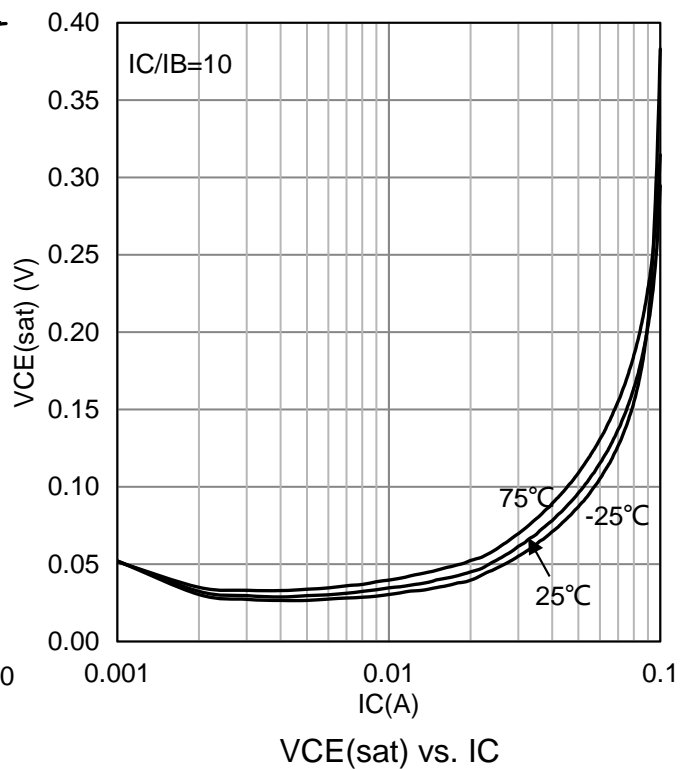
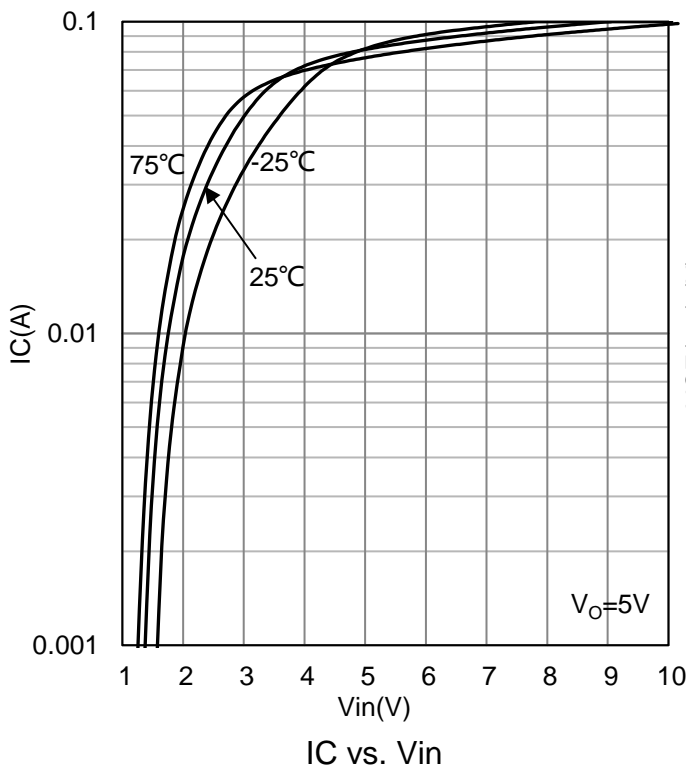
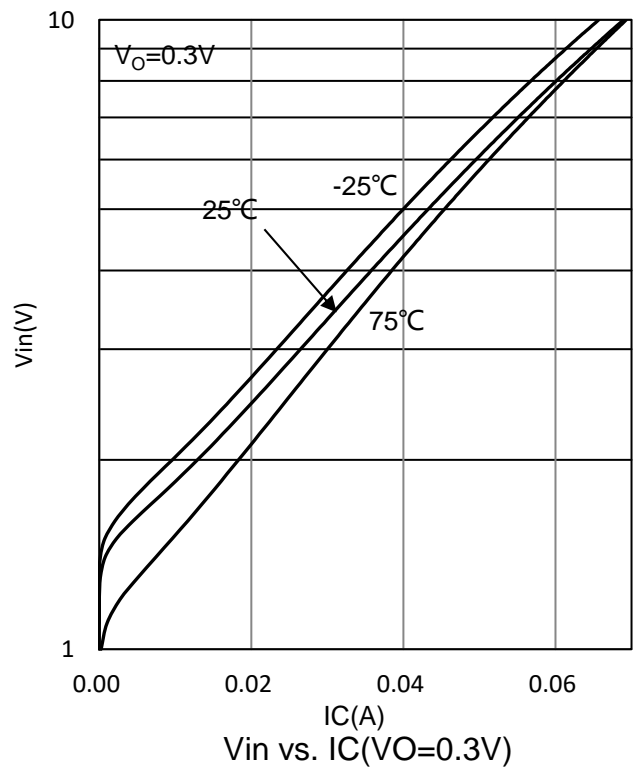
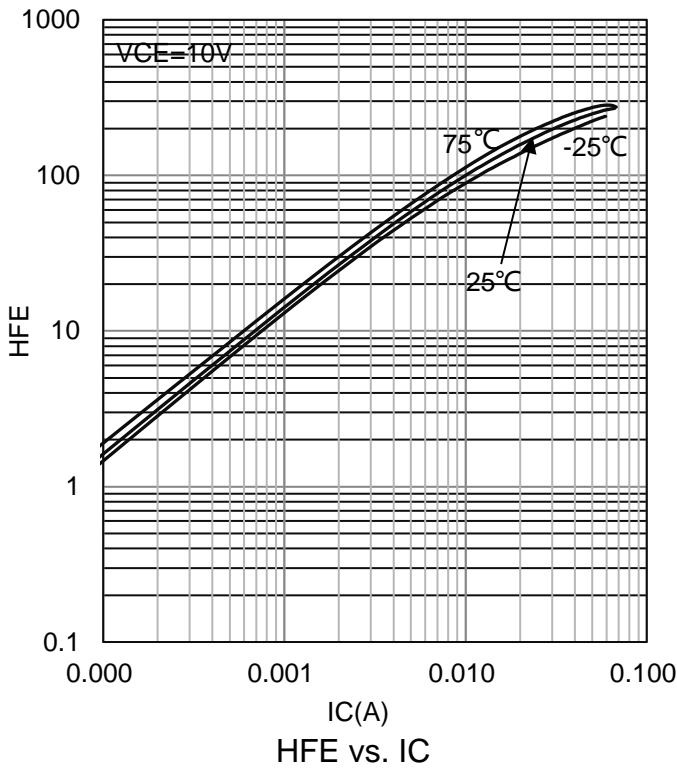

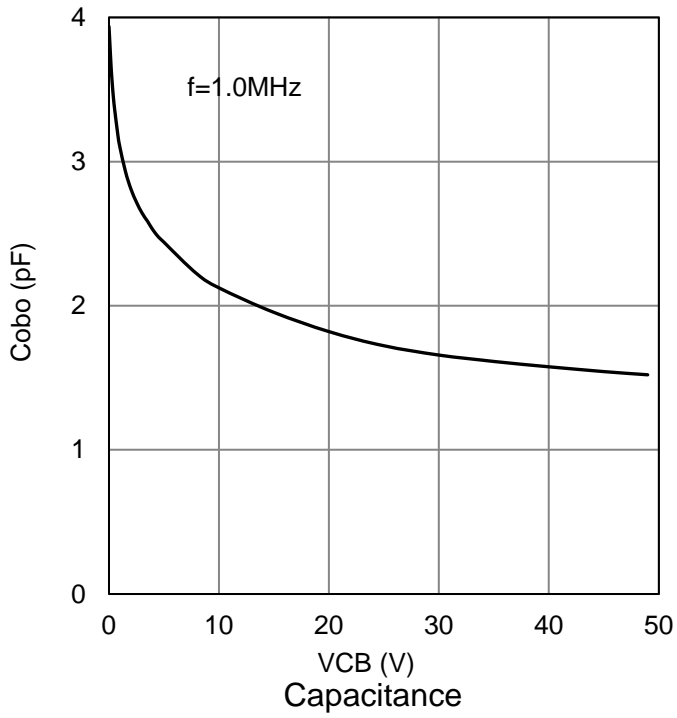
6.ELECTRICAL CHARACTERISTICS CURVES(Con.)

7.OUTLINE AND DIMENSIONS

Notes:

1. DIMENSIONING AND TOLERANCING PER ANSI Y14.5M, 1982.
2. CONTROLLING DIMENSION: MILLIMETERS.
3. MAXIMUM LEAD THICKNESS INCLUDES LEAD FINISH. MINIMUM LEAD THICKNESS IS THE MINIMUM THICKNESS OF BASE MATERIAL.
4. DIMENSIONS D AND E1 DO NOT INCLUDE MOLD FLASH, PROTRUSIONS OR GATE BURRS.

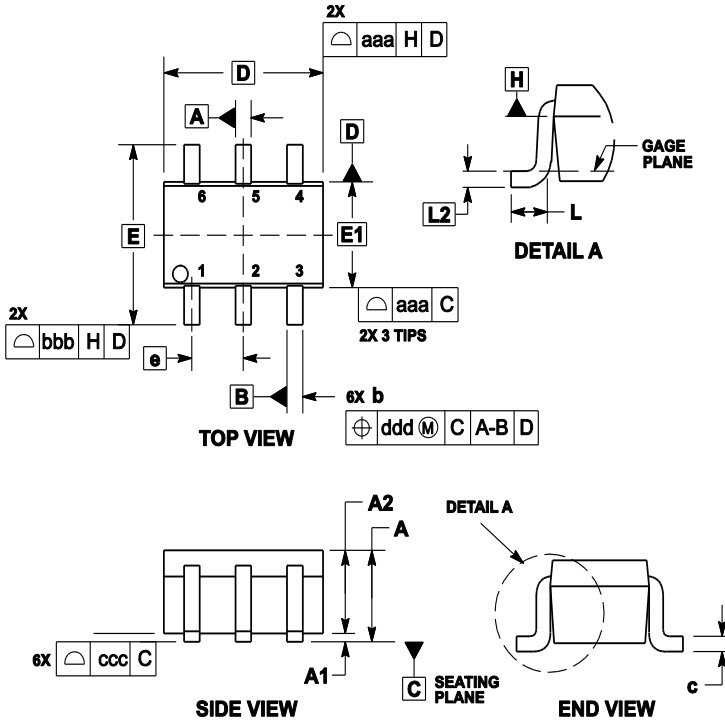

DIM	MILLIMETERS			INCHES		
	MIN	NOM	MAX	MIN	NOM	MAX
A	---	---	1.10	---	---	0.043
A1	0.00	---	0.10	0	---	0.004
A2	0.70	0.90	1.00	0.027	0.035	0.039
b	0.15	0.20	0.25	0.006	0.008	0.01
C	0.08	0.15	0.22	0.003	0.006	0.009
D	1.80	2.00	2.20	0.07	0.078	0.086
E	2.00	2.10	2.20	0.078	0.082	0.086
E1	1.15	1.25	1.35	0.045	0.049	0.053
e	0.65 BSC			0.026 BSC		
L	0.26	0.36	0.46	0.010	0.014	0.018
L2	0.15 BSC			0.006 BSC		
aaa	0.15			0.01		
bbb	0.30			0.01		
ccc	0.10			0.00		
ddd	0.10			0.00		

8.SOLDERING FOOTPRINT

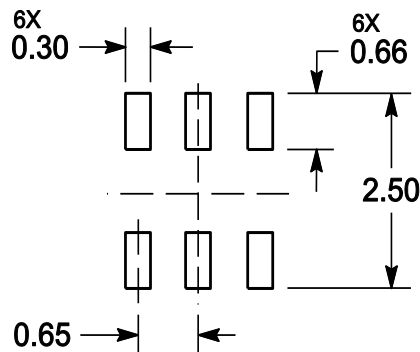

DISCLAIMER

- Curve guarantee in the specification. The curve of test items with electric parameter is used as quality guarantee. The curve of test items without electric parameter is used as reference only.
- Before you use our Products for new Project, you are requested to carefully read this document and fully understand its contents. LRC shall not be in any way responsible or liable for failure, malfunction or accident arising from the use of any LRC's Products against warning, caution or note contained in this document.
- All information contained in this document is current as of the issuing date and subject to change without any prior notice. Before purchasing or using LRC's Products, please confirm the latest information with a LRC sales representative.