

# LBAS70-06LT1G

## S-LBAS70-06LT1G

Schottky barrier diode

### 1. FEATURES

- Low forward current
- High breakdown voltage
- Guard ring protected
- Low diode capacitance.
- We declare that the material of product compliance with RoHS requirements and Halogen Free.
- S- prefix for automotive and other applications requiring unique site and control change requirements; AEC-Q101 qualified and PPAP capable.

### 2. APPLICATIONS

- Ultra high-speed switching
- Voltage clamping
- Protection circuits.

### 3. DEVICE MARKING AND RESISTOR VALUES

Device	Marking	Shipping
LBAS70-06LT1G	GK	3000/Tape&Reel
LBAS70-06LT3G	GK	10000/Tape&Reel

### 4. MAXIMUM RATINGS(Ta = 25°C)

Parameter	Symbol	Limits	Unit
Continuous reverse voltage	VR	70	V
Continuous forward current	IF	70	mA
Repetitive Peak forward surge current(tp ≤ 1s, δ ≤ 0.5)	IFRM	70	mA
Non-repetitive peak forward current (tp < 10ms)	IFSM	100	mA
Storage temperature	Tstg	-65~+150	°C
Junction temperature	Tj	150	°C
Operating ambient temperature	Tamb	-65~+150	°C

### 5. THERMAL CHARACTERISTICS

Parameter	Symbol	Limits	Unit
Thermal resistance from junction to ambient (Note 1)	RθJA	500	°C/W

1. Refer to SOT23 or SOT143B standard mounting conditions.

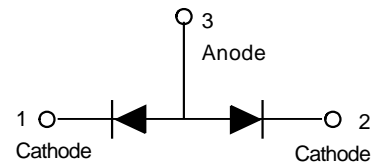
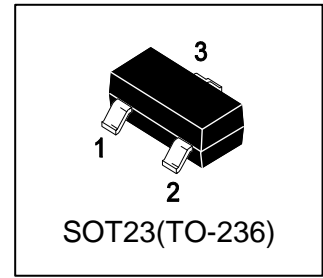

**6. ELECTRICAL CHARACTERISTICS (Ta= 25°C)**

CHARACTERISTICS	Symbol	Limits	Unit
Forward voltage (IF =1mA)	VF	410	mV
(IF =10mA)		750	mV
(IF =15mA)		1	V
Reverse current(Note 2) (VR=50V)	IR	100	nA
(VR=70V)		10	μA
Charge carrier life time (IF =5mA)	τ	100	pS
Diode capacitance (f=1MHz,VR =0)	Cd	2	pF

2.Pulse test:tp =300μs,δ=0.02.

**7. ELECTRICAL CHARACTERISTICS CURVES**

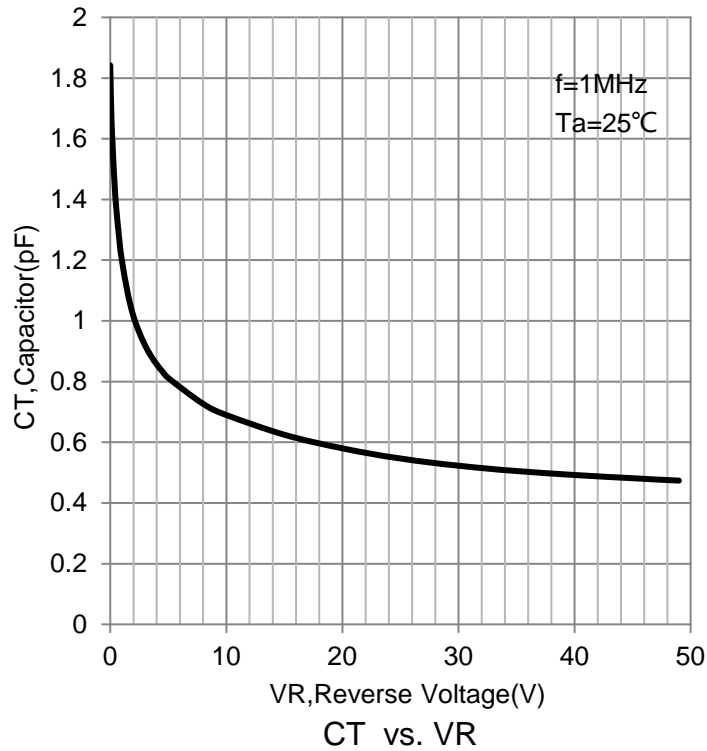
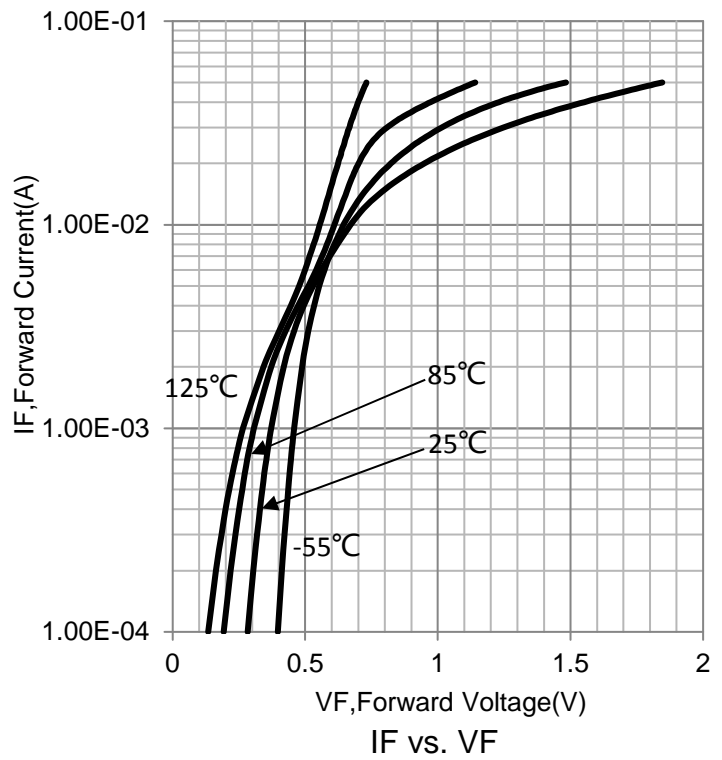
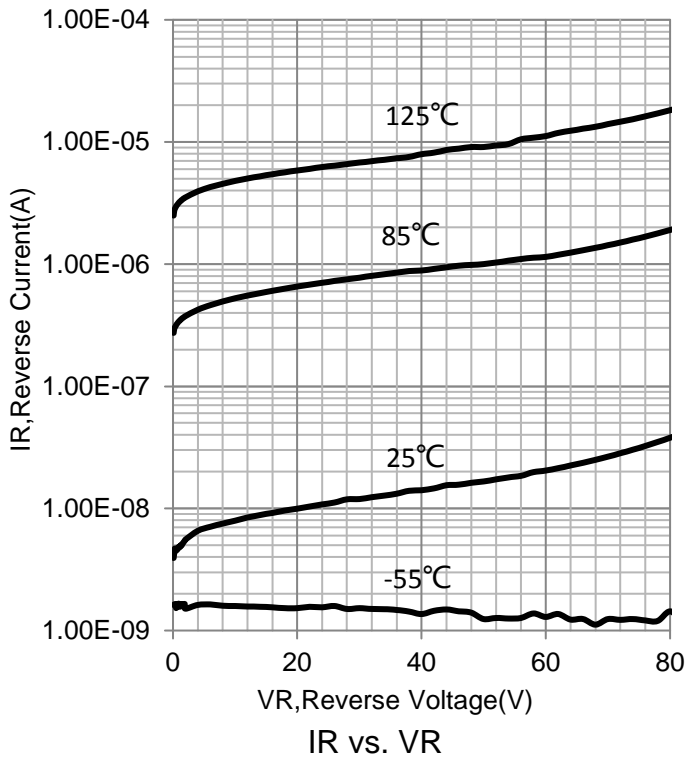

### 8. OUTLINE AND DIMENSIONS

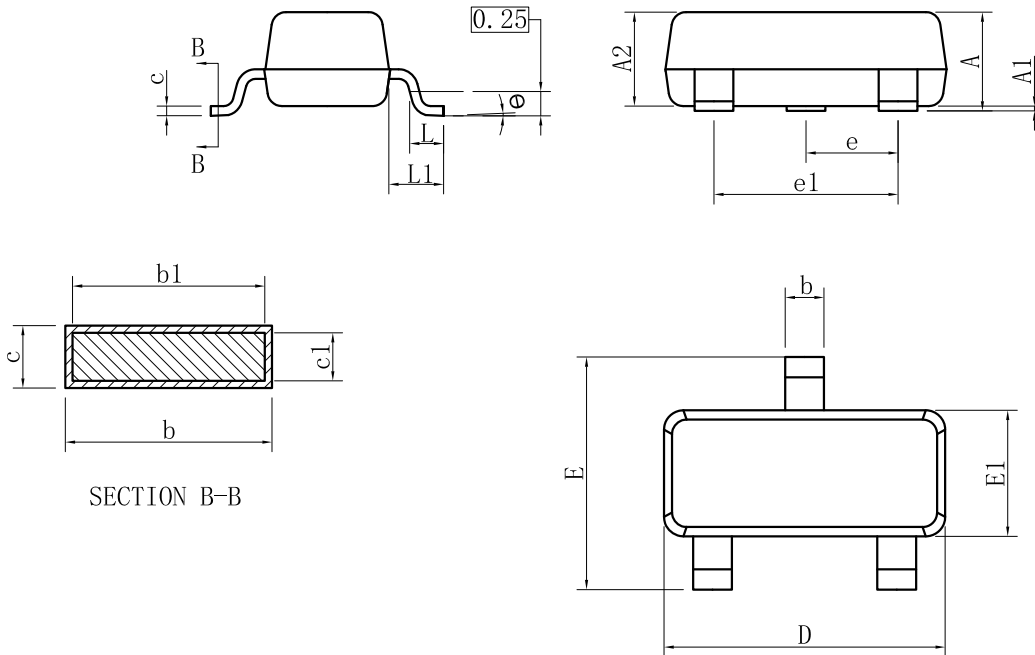

SOT23			
DIM	MIN	NOR	MAX
A	0.89	-	1.12
A1	0.01	-	0.10
A2	0.88	0.95	1.02
b	0.30	-	0.50
b1	0.30	0.40	0.45
c	0.08	-	0.20
c1	0.08	0.10	0.16
D	2.80	2.90	3.04
E	2.10	-	2.64
E1	1.20	1.30	1.40
e	0.95BSC		
e1	1.90BSC		
L	0.40	0.46	0.60
L1	0.54REF		
θ	0°	-	8°
All Dimensions in mm			

#### GENERAL NOTES

1. Top package surface finish Ra0.4±0.2um
2. Bottom package surface finish Ra0.7±0.2um
3. Side package surface finish Ra0.4±0.2um

### 9. SOLDERING FOOTPRINT

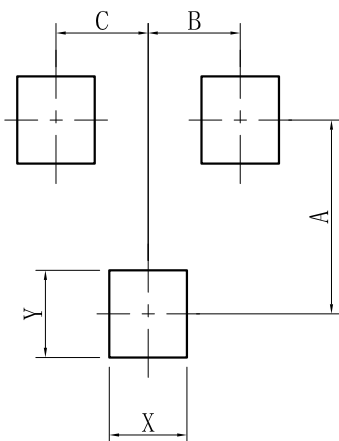

SOT-23	
DIM	(mm)
X	0.80
Y	0.90
A	2.00
B	0.95
C	0.95

## **DISCLAIMER**

- Curve guarantee in the specification. The curve of test items with electric parameter is used as quality guarantee. The curve of test items without electric parameter is used as reference only.
- Before you use our Products for new Project, you are requested to carefully read this document and fully understand its contents. LRC shall not be in any way responsible or liable for failure, malfunction or accident arising from the use of any LRC's Products against warning, caution or note contained in this document.
- All information contained in this document is current as of the issuing date and subject to change without any prior notice. Before purchasing or using LRC's Products, please confirm the latest information with a LRC sales representative.